



**TEST REPORT**

FORM 200-E

PAGE: 1/5

<b>1. Report Reference No:</b>  <b>504231-E</b>	<b>2. Date of Issue:</b>  05/12/2016
<b>3. Applicant's name</b> .....	<b>DIMITRIOS IOAN. PATERDIS</b>  <b>(BAUER SOLAR SYSTEMS)</b>
<b>4. Address</b> .....	Chr. Smirnis 27, 134 51, Zefyrio, Attiki, Greece
<b>Tel.</b> .....	+30 2102621742-3
<b>Mob. Tel.</b> .....	---
<b>Fax.</b> .....	+30 2102322185
<b>E-mail</b> .....	<a href="mailto:info@bauer.gr">info@bauer.gr</a>
<b>Url</b> .....	<a href="http://bauerhellas.com">http://bauerhellas.com</a>
<b>5. Applicant's VAT No.</b> .....	022206222
<b>Tax service</b> .....	Agion Anargyron
<b>6. Applicant's agreement, contract or application</b> .....	Form 300 with Reference No: 791 / 20.10.2016
<b>7. Testing Laboratory</b> .....	HEEQAC S.A.
<b>8. Address</b> .....	103, Kefallinias Str., 112 51 Athens, Greece
<b>9. Testing/ Inspection premises location/address</b> .....	<input checked="" type="checkbox"/> 103, Kefallinias Str., 112 51 Athens, Greece  <input type="checkbox"/> 36 <sup>th</sup> Klm. Markopoulou - Oropou, 190 15 Attiki, Greece



**TEST REPORT**

**FORM 200-E**

**PAGES: 2/5**

**LAB RECORD S/N: 504231-E**

**10. Directive(s) / Regulation(s) .....: LVD 2014/35/EU**

**11. Test specification (s):**

**Standard(s) /Normative documents .....: EN 60335-1:2012 +A11 :2014 + AC:2014  
(IEC 60335-1:2010 +A1 :2013)  
  
EN 60335-2-21:2003 +A1:2004 +A2:2008  
(IEC 60335 2-21:2002 +A1:2004 +A2:2008)**

**Test Procedure .....: As above standards**

**Procedure's deviation(s) .....: -----**

**Non-standard test method(s) .....: -----**

**12. Test item description .....: Solar water heater tank**

**13. Trade Mark .....:**



**14. Manufacturer .....: DIMITRIOS IOAN. PATERDIS  
(BAUER SOLAR SYSTEMS)**

**Address.....: Chr. Smirnis 27, 134 51, Zefyrio, Attiki,  
Greece**

**15. Type/Model reference .....: VR:300 Glass/VR:250 Glass, VR:200 Glass,  
VR:160 Glass, VR:120 Glass, VR:300 Inox  
VR:250 Inox, VR:200 Inox, VR:160 Inox,  
VR:120 Inox.**

**Hardware version ---**

**Software version ---**

**Accessories ---**

**16. Ratings .....: 230V~, 4000W, 50Hz, 1MPa, IP24**

**17. Serial Number(s) : 10201601**



# TEST REPORT

FORM 200-E

PAGES: 3/5

LAB RECORD S/N: **504231-E**

18. Number of samples .....: One (1)
19. Sampling procedure .....: -----
20. Test item's(s') receipt date .....: 20/10/2016
21. Testing Period .....: 20/10/2016 up to 01/12/2016

## 22. Conclusions - Results:

The test item complies with the requirements of EN 60335-1:2012 +A11 :2014 + AC:2014 (IEC 60335-1:2010 +A1 :2013) and EN 60335-2-21:2003 +A1:2004 +A2:2008 (IEC 60335 2-21:2002 +A1:2004 +A2:2008) standards with which it was tested, as in the following summary.

All respective tests were applied to type **VR:300 Glass** as defined by the manufacturer. Nine (9) more models are documented for compliance with the above mentioned standards by the manufacturer on the basis of this report. These models which have similar electrical/electronic construction and their differences, as stated by the manufacturer, are as follows:

A/N	MODEL	RATED POWER (kW)	CAPACITY (L)	Class	IP
1	VR:300 Glass	4	300	I	24
2	VR:300 Inox	4	300	I	24
3	VR:250 Glass	4	250	I	24
4	VR:250 Inox	4	250	I	24
5	VR:200 Glass	4	200	I	24
6	VR:200 Inox	4	200	I	24
7	VR:160 Glass	4	160	I	24
8	VR:160 Inox	4	160	I	24
9	VR:120 Glass	4	120	I	24
10	VR:120 Inox	4	120	I	24



# TEST REPORT

FORM 200-E

PAGES: 4/5

LAB RECORD S/N:

**504231-E**

## 23. Summary of testing:

EN 60335-1:2012 +A11 :2014 + AC:2014 (IEC 60335-1:2010 +A1:2013) EN 60335-2-21:2003 +A1:2004 +A2:2008 (IEC 60335 2-21:2002 +A1:2004 +A2:2008)							
No	Par. No.	Description	Verdict	No	Par. No.	Description	Verdict
1.	5	General conditions for the tests	P	2.	30	Resistance to heat and fire	P
3.	6	Classification	P	4.	31	Resistance to rusting	P
5.	7	Marking and instructions	P	6.	32	Radiation, toxicity and similar hazards	P
7.	8	Protection against access to live parts	P	8.	Annex A	Routine tests	NA
9.	10	Power input and current	P	10.	Annex B	Appliances powered by rechargeable batteries	NA
11.	11	Heating	P	12.	Annex C	Ageing test on motors	NA
13.	13	Leakage current and electric strength at operating temperature	P	14.	Annex D	Thermal motor protectors	NA
15.	14	Transient overvoltages	NA	16.	Annex E	Needle flame test	NA
17.	15	Moisture resistance	P	18.	Annex F	Capacitors	NA
19.	16	Leakage current and electric strength	P	20.	Annex G	Safety isolating transformers	NA
21.	17	Overload protection of transformers and associated circuits	NA	22.	Annex H	Switches	NA
23.	19	Abnormal operation	P	24.	Annex I	Motors having basic insulation that is inadequate for the rated voltage of the appliance	NA
25.	20	Stability and mechanical hazards	NA	26.	Annex J	Coated printed circuit boards	NA
27.	21	Mechanical strength	P	28.	Annex K	Overvoltage categories	P
29.	22	Construction	P	30.	Annex L	Guidance for the measurement of clearances and creepage distances	P
31.	23	Internal wiring	P	32.	Annex M	Pollution degree	P
33.				34.			
35.	24	Components	P	36.	Annex N	Proof tracking test	NA
37.	25	Supply connection and external flexible cords	P	38.	Annex O	Selection and sequence of the tests of clause 30	P
39.	26	Terminals for external conductors	P	40.	Annex P	Guidance for the application of this standard to appliances used in warm damp equable climates	NA
41.	27	Provision for earthing	P	42.	Annex Q	Sequence of tests for the evaluation of electronic circuits	NA
43.	28	Screws and connections	P	44.	Annex R	SOFTWARE EVALUATION	NA
45.	29	Clearances, creepage distances and solid insulation	P				



**TEST REPORT**

**FORM 200-E**

**PAGES: 5/5**

**LAB RECORD S/N:**

**504231-E**

**24. Attachments :**

1. Form 201-4117-TRF-E	Pages:	85
4. Form 202-E	Pages:	06
5. Form 203-E	Pages:	07
6. This Form 200-E	Pages:	05

**25. Total Number of pages in this Report .....: 103**

**26. Notes:**

- The test results presented in this report relate only to the samples tested.
- This report is issued and forwarded to the applicant electronically (secure PDF). It is only a valid copy if it is viewed in PDF format with the following security options not allowed: Changing the document, content copying, Page extraction, Adding or changing notes and form fields.
- Electronic file copies of the photographs are included with the electronic file copy of this report. A complete copy of this report in electronic form (secure PDF) also remains in HEEQAC SA.
- Throughout this report a  comma /  point is used as the decimal separator.
- Reproduction of the complete report is permitted. Reproduction of any part of this report is not permitted without the written approval of HEEQAC SA.
- All rights of exploitation in any form and by any means reserved by HEEQAC SA.

**27. Compiled by:**

**CHACHLAKIS GEORGE  
ELECTRONICS ENGINEER**

**+ Signature:**

**28. Approved by:**

**CHRYSANTHAKOPOULOS GEORGE  
GENERAL MANAGER**

**+ Signature:**





**LAB TEST REPORT**  
FORM 201-4117-TRF-E

page: 1/85

Lab Record S/N **504231-E**

Type of test object: Solar water heater tank	Model/Type: <b>VR:300 Glass</b>	S/N: 10201601
--	---------------------------------	---------------

In this Report the following terms and verdicts were used Comply .....: P Not Comply .....: FAIL Not Applicable.....: NA Not Tested .....: NT	Test Date FROM 20/10/2016 UP TO 01/12/2016
---	--

Tests were performed by

Signature **CHACHLAKIS GEORGE**  
**ELECTRONICS ENGINEER**

<input checked="" type="checkbox"/> EN 60335-1:2012 +A11 :2014 + AC:2014	<input checked="" type="checkbox"/> IEC 60335-1:2010 +A1 :2013
<input checked="" type="checkbox"/> EN 60335-2-21:2003 +A1:2004 +A2:2008	<input checked="" type="checkbox"/> IEC 60335 2-21:2002 +A1:2004 +A2:2008

Seq. No	Paragraphs	Requirements	Results Measurements Remarks	Verdict
	5	<b>GENERAL CONDITIONS FOR THE TESTS</b>		
1.		Tests performed according to cl. 5, e.g. nature of supply, sequence of testing, etc.		<b>P</b>
	6	<b>CLASSIFICATION</b>		
2.	6.1 (EN 60335-2-21)	Water heaters shall be class I, class II or class III.....:	Class I	<b>P</b>
3.	6.2	Protection against harmful ingress of water	IP24	<b>P</b>
4.	6.2 (EN 60335-2-21)	Water heaters for installation outdoors shall be at least IPX4. Other water heaters shall be at least IPX1.	IP24	<b>P</b>
	7	<b>MARKING AND INSTRUCTIONS</b>		
5.	7.1	Rated voltage or voltage range (V).....:	230V~	<b>P</b>
6.		Nature of supply unless rated frequency is marked(Hz).....:	50 Hz	<b>P</b>
7.		Rated power input (W) or Rated current (A) .....	4000W	<b>P</b>
8.		Manufacturer's or responsible vendor's name, trademark or identification mark.....:	See copy of marking plate in attached form 202.	<b>P</b>

[Q.M.

- HEEQAC S.A -

( FORM APPROVAL : 01/02/2015

ISSUE :1)]

103, KEFALLINIAS STR., 112 51 ATHENS GREECE – TEL.: +30-210-86.70.588 – FAX: +30-210-86.47.510

e-mail: info@heeqac.gr - website: [www.heeqac.gr](http://www.heeqac.gr)



**LAB RECORDS**  
**FORM 201-4117-TRF-E**

page: 2/85

(Lab Record S/N):

**504231-E**

Seq. No	Paragraphs	Requirements	Results Measurements Remarks	Verdict
9.		Model or type reference.....:	See copy of marking plate in attached form 202.	P
10.		Symbol 5172 of IEC 60417, for Class II appliances		NA
11.		IP number, other than IPX0.....:	IP24	P
12.		Symbol 5180 of IEC 60417, for Class III appliances		NA
13.		Appliances intended to be connected to the supply mains, shall cover: – 230 V for single-phase appliances; – 400 V for multi-phase appliances	230	P
14.		Symbol IEC 60417-5036, for the enclosure of electrically-operated water valves in external hose-sets for connection of an appliance to the water mains		NA
15.	7.1 (EN 60335-2-21)	If not cistern type water heater - marked with the rated pressure in pascals.	1Mpa	P
16.	7.1 (EN 60335-2-21)	Marked with rated capacity in litres.	See copy of marking plate in attached form 202.	P
17.	7.1 (EN 60335-2-21)	Closed water heaters marked with statement: pressure-relief device is to be fitted in the installation, unless it is incorporated in the appliance.		P
18.	7.1 (EN 60335-2-21)	Closed water heaters with less than 0,6MPa rated pressure and low pressure water heaters marked with the statement: pressure reducing valve is to be fitted in the installation.		NA
19.	7.1 (EN 60335-2-21)	Open-outlet water heaters marked close to the outlet or on tag attached with the following: WARNING: This outlet acts as a vent and must only be connected to a fitting recommended by the manufacturer. It must not be connected to a tap.		NA
20.	7.2	Warning for stationary appliances for multiple supply		NA
21.		Warning placed in vicinity of terminal cover		NA
22.	7.3	Range of rated values marked with the lower and upper limits separated by a hyphen		NA
23.		Different rated values marked with the values separated by an oblique stroke		NA



**LAB RECORDS**  
**FORM 201-4117-TRF-E**

page: 3/85

(Lab Record S/N):

**504231-E**

Seq. No	Paragraphs	Requirements	Results Measurements Remarks	Verdict
24.	7.4	Appliances adjustable for different rated voltages, the voltage setting is clearly discernible		NA
25.		Requirement met if frequent changes are not required and the rated voltage to which the appliance is to be adjusted is determined from a wiring diagram		NA
26.	7.5	Appliances with more than one rated voltage or one or more rated voltage ranges, marked with rated input or rated current for each rated voltage or range, unless		NA
27.		the power input is related to the arithmetic mean value of the rated voltage range		NA
28.		Relation between marking for upper and lower limits of rated power input or rated current and voltage is clear		NA
29.	7.6	Correct symbols used		P
30.		The symbol for nature of supply is placed next to the marking for rated voltage	230V~	P
31.		The symbol for class II appliances is placed so that it will be obvious that it is a part of the technical information and is unlikely to be confused with any other marking		NA
32.		Units of physical quantities and their symbols are those of the international standardized system		P
33.	7.7	Connection diagram fixed to appliances to be connected to more than two supply conductors and appliances for multiple supply	The correct mode of connection is obvious	NA
	7.8	Except for type Z attachment, terminals for connection to the supply mains indicated as follows:		
34.		- marking of terminals exclusively for the neutral conductor (N)		NA
35.		- marking of protective earthing terminals (symbol 5019 of IEC 60417)		P
36.		- marking not placed on removable parts		NA
37.	7.9	Marking or placing of switches which may cause a hazard		NA
38.		Indications used for this purpose are, wherever practicable, comprehensible		NA



**LAB RECORDS**  
**FORM 201-4117-TRF-E**

**(Lab Record S/N): 504231-E**

Seq. No	Paragraphs	Requirements	Results Measurements Remarks	Verdict
		without a knowledge of languages or national standards		
39.	7.10	Indications of switches on stationary appliances and controls on all appliances by use of figures, letters or other visual means.....:		NA
40.		The figure 0 indicates only OFF position, unless no confusion with the OFF position		NA
41.		Devices used to start/stop operational functions of the appliance, if any, shall be distinguished from other manual devices		NA
42.		An indication that the device has been operated shall be given by a tactile feedback or an audible and visual feedback.		NA
43.		A selector switch with an off-position clearly identifiable is allowed.		NA
44.		An ON/OFF switch, if any, is considered a suitable device to stop operational functions. A plug is not considered a suitable device to stop operational functions, as it can be difficult to be reached by vulnerable persons.		NA
45.	7.11	Indication for direction of adjustment of controls		NA
46.	7.12	Instructions for safe use provided		P
47.		Appropriate details are given, if it is necessary to take precautions during user maintenance		P
		The instructions state that:		
48.		This appliance can be used by children aged from 8 years and above and persons with reduced physical, sensory or mental capabilities or lack of experience and knowledge if they have been given supervision or instruction concerning use of the appliance in a safe way and understand the hazards involved. Children shall not play with the appliance. Cleaning and user maintenance shall not be made by children without supervision.		NA



**LAB RECORDS**  
**FORM 201-4117-TRF-E**

page: 5/85

**(Lab Record S/N): 504231-E**

Seq. No	Paragraphs	Requirements	Results Measurements Remarks	Verdict
49.		The instructions for appliances having a part of class III construction supplied from a detachable power supply unit shall state that the appliance is only to be used with the power supply unit provided with the appliance.		<b>NA</b>
50.		The instructions for class III appliances shall state that it must only be supplied at safety extra low voltage corresponding to the marking on the appliance. This instruction is not necessary for battery-operated appliances if the battery is a primary battery or secondary battery charged outside of the appliance.		<b>NA</b>
51.	7.12.Z1	The specific instructions related to the safe operation of this appliance (as given in 7.12 of this standard) shall be collated together in the front section of the user instructions.  The height of the characters, measured on the capital letters, shall be at least 3 mm.		<b>P</b>
52.		These instructions shall also be available in an alternative format	Hardcopy and Electronic (PDF)	<b>P</b>
53.	7.12 (EN 60335-2-21)	The instructions for closed water heaters shall state the substance of the following:		<b>P</b>
54.	7.12 (EN 60335-2-21)	– the water may drip from the discharge pipe of the pressure-relief device and that this pipe must be left open to the atmosphere		<b>P</b>
55.	7.12 (EN 60335-2-21)	– the pressure-relief device is to be operated regularly to remove lime deposits and to verify that it is not blocked		<b>P</b>
56.	7.12 (EN 60335-2-21)	– how the water heater can be drained		<b>P</b>
57.	7.12.1	Sufficient details for installation supplied		<b>P</b>
58.	7.12.1 (EN 60335-2-21)	The installation instructions shall state the substance of the following:		<b>P</b>
59.	7.12.1 (EN 60335-2-21)	– the type or characteristics of the pressure-relief device and how to connect it, unless it is incorporated in the appliance		<b>P</b>
60.	7.12.1 (EN 60335-2-21)	– a discharge pipe connected to the pressure-relief device is to be installed in a continuously downward direction		<b>P</b>



**LAB RECORDS**  
**FORM 201-4117-TRF-E**

page: 6/85

(Lab Record S/N):

**504231-E**

Seq. No	Paragraphs	Requirements	Results Measurements Remarks	Verdict
		and in a frost-free environment		
61.	7.12.1 (EN 60335-2-21)	– the type or characteristics of a pressure reducing valve and the installation details (for appliances having a rated pressure less than 0,6 MPa)		NA
62.	7.12.1 (EN 60335-2-21)	The instructions for closed water heaters incorporating a heat exchanger shall give details on the installation of control devices and the temperature settings that are necessary to prevent operation of the thermal cut-out caused by the heat from the exchanger.		P
63.	7.12.1 (EN 60335-2-21)	The instructions for cistern-fed water heaters and low-pressure water heaters shall contain the substance of the following: WARNING: Do not connect any pressure-relief device to the vent pipe of this water heater.		NA
64.	7.12.2	Stationary appliances not fitted with means for disconnection from the supply mains having a contact separation in all poles that provide full disconnection under overvoltage category III, the instructions state that means for disconnection must be incorporated in the fixed wiring in accordance with the wiring rules		P
65.	7.12.3	Insulation of the fixed wiring in contact with parts exceeding 50 K during clause 11; instructions stating that the fixed wiring must be protected		NA
	7.12.4	Instructions for built-in appliances:		
66.		- dimensions of space		NA
67.		- dimensions and position of supporting means		NA
68.		- distances between parts and surrounding structure		NA
69.		- dimensions of ventilation openings and arrangement		NA
70.		- connection to supply mains and interconnection of separate components		NA
71.		- allow disconnection of the appliance after installation, by accessible plug or a switch in the fixed wiring, unless		NA

[Q.M.

- HEEQAC S.A -

( FORM APPROVAL : 01/02/2015



ISSUE :1)]

**LAB RECORDS**  
**FORM 201-4117-TRF-E**

page: 7/85

**(Lab Record S/N):**

**504231-E**

Seq. No	Paragraphs	Requirements	Results Measurements Remarks	Verdict
72.		a switch complying with 24.3		NA
73.	7.12.5	Replacement cord instructions, type X attachment with a specially prepared cord		NA
74.		Replacement cord instructions, type Y attachment		P
75.		Replacement cord instructions, type Z attachment		NA
76.	7.12.6	Caution in the instructions for heating appliances with a non-self-resetting thermal cut-out		NA
77.	7.12.7	Instructions for fixed appliances stating how the appliance is to be fixed		P
	7.12.8	Instructions for appliances connected to the water mains:		
78.		- max. inlet water pressure (Pa)..... :	0,6	P
79.		- min. inlet water pressure, if necessary (Pa)..... :		NA
80.		Instructions concerning new and old hose-sets for appliances connected to the water mains by detachable hose-sets.		NA
81.	7.13	Instructions and other texts in an official language		P
82.	7.14	Marking clearly legible and durable		P
83.	7.15	Marking on a main part		P
84.		Marking clearly discernible from the outside, if necessary after removal of a cover		P
85.		For portable appliances, cover can be removed or opened without a tool		NA
86.		For stationary appliances, name, trademark or identification mark and model or type reference visible after installation		P
87.		For fixed appliances, name, trademark or identification mark and model or type reference visible after installation according to the instructions		P
88.		Indications for switches and controls placed on or near the components. Marking not on parts which can be positioned or repositioned in such a way that the marking is misleading.		NA



**LAB RECORDS**  
**FORM 201-4117-TRF-E**

page: 8/85

(Lab Record S/N):

**504231-E**

Seq. No	Paragraphs	Requirements	Results Measurements Remarks	Verdict
89.	7.16	Marking of a possible replaceable thermal link or fuse link clearly visible with regard to replacing the link.		NA
90.	7.101 (EN 60335-2-21)	The water inlet and the water outlet shall be identified.		P
91.	7.101 (EN 60335-2-21)	This identification shall not be on detachable parts.		P
92.	7.101 (EN 60335-2-21)	If colors are used, blue shall be used for the inlet and red for the outlet.		P
	<b>8</b>	<b>PROTECTION AGAINST ACCESS TO LIVE PARTS</b>		
93.	8.1	Adequate protection against accidental contact with live parts		P
94.	8.1.1	Requirement applies for all positions, detachable parts removed		P
95.		Insertion or removal of lamps, protection against contact with live parts of the lamp cap		NA
96.		Use of test probe B of IEC 61032: no contact with live parts		P
97.	8.1.2	Use of test probe 13 of IEC 61032 through openings in class 0 appliances and class II appliances/ constructions: no contact with live parts		NA
98.		Test probe 13 also applied through openings in earthed metal enclosures having a non-conductive coating: no contact with live parts		NA
99.	8.1.3	For appliances other than class II, use of test probe 41 of IEC 61032: no contact with live parts of visible glowing heating elements		NA
100.	8.1.4	Accessible part not considered live if:		
101.		- safety extra-low a.c. voltage: peak value not exceeding 42.4 V		NA
102.		- safety extra-low d.c. voltage: not exceeding 42.4 V		NA
103.		- or separated from live parts by protective impedance		NA
104.		If protective impedance: d.c. current not exceeding 2 mA, and		NA
105.		a.c. peak value not exceeding 0.7 mA		NA
106.		- for peak values over 42.4 V up to and including 450 V, capacitance not		NA

[Q.M.

- HEEQAC S.A -

( FORM APPROVAL : 01/02/2015



ISSUE :1)]

**LAB RECORDS**  
**FORM 201-4117-TRF-E**

page: 9/85

(Lab Record S/N):

**504231-E**

Seq. No	Paragraphs	Requirements	Results Measurements Remarks	Verdict
		exceeding 0,1 $\mu$ F		
107.		- for peak values over 450 V up to and including 15 kV, discharge not exceeding 45 $\mu$ C		NA
108.		- for peak values over 15kV, the energy in the discharge not exceeding 350 mJ		NA
	8.1.5	Live parts protected at least by basic insulation before installation or assembly:		
109.		- built-in appliances		NA
110.		- fixed appliances		P
111.		- appliances delivered in separate units		NA
112.	8.2	Class II appliances and constructions constructed so that there is adequate protection against accidental contact with basic insulation and metal parts separated from live parts by basic insulation only		NA
113.		Only possible to touch parts separated from live parts by double or reinforced insulation		NA
	10	<b>POWER INPUT AND CURRENT</b>		
114.	10.1	Power input at normal operating temperature, rated voltage and normal operation not deviating from rated power input by more than shown in table 1	see appended table 10.1	P
115.		Test for an appliance with one or more rated voltage ranges		NA
116.	10.2	Current at normal operating temperature, rated voltage and normal operation not deviating from rated current by more than shown in table 2		NA
117.		Test for an appliance with one or more rated voltage ranges		NA
	11	<b>HEATING</b>		
118.	11.1	No excessive temperatures in normal use	(see appended table 11.8)	P
119.	11.3	Temperature rises, other than of windings, determined by thermocouples		P
120.		Temperature rises of windings determined by resistance method,		NA

[Q.M.

- HEEQAC S.A -

( FORM APPROVAL : 01/02/2015



ISSUE :1])



**LAB RECORDS**  
**FORM 201-4117-TRF-E**

page: 11/85

(Lab Record S/N):

**504231-E**

Seq. No	Paragraphs	Requirements	Results Measurements Remarks	Verdict
136.		Protective impedance and radio interference filters disconnected before carrying out the tests		NA
137.	13.2	For class 0 appliances, class II appliances and class III appliances, leakage current measured by means of the circuit described in figure 4 of IEC 60990		NA
138.		For other appliances, a low impedance ammeter capable of measuring the true r.m.s. value of the leakage current may be used.		P
139.		Leakage current measurements	See Table 13.2	P
140.	13.3	The appliance is disconnected from the supply		P
141.		Electric strength tests according to table 4	See Table 13.3	P
142.		No breakdown during the tests		P
	14	<b>TRANSIENT OVERVOLTAGES</b>		
143.		Appliances withstand the transient overvoltages to which they may be subjected		NA
144.		Clearances having a value less than specified in table 16 subjected to an impulse voltage test, the test voltage specified in table 6		NA
145.		No flashover during the test, unless of functional insulation		NA
146.		In case of flashover of functional insulation, the appliance complies with clause 19 with the clearance short circuited		NA
	15	<b>MOISTURE RESISTANCE</b>		
147.	15.1	Enclosure provides the degree of moisture protection according to classification of the appliance	IP24	P
148.		Compliance checked as specified in 15.1.1, taking into account 15.1.2, followed by the electric strength test of 16.3		P
149.		No trace of water on insulation which can result in a reduction of clearances and creepage distances below values specified in clause 29		P



**LAB RECORDS**  
**FORM 201-4117-TRF-E**

page: 12/85

(Lab Record S/N):

**504231-E**

Seq. No	Paragraphs	Requirements	Results Measurements Remarks	Verdict
150.	15.1.1	Appliances, other than IPX0, subjected to tests as specified in IEC 60529..... :	IP24	P
151.		Water valves in external hoses for connection of an appliance to the water mains tested as specified for IPX7 appliances		NA
152.	15.1.2	Hand-held appliance turned continuously through the most unfavourable positions during the test		NA
153.		Built-in appliances installed according to the instructions		NA
154.		Appliances with an automatic cord reel are tested with the cord in the most unfavourable position in such a way that the reeling of the wet cord may affect electrical insulation during operation. The cord shall not be dried before reeling		NA
155.		Appliances placed or used on the floor or table placed on a horizontal unperforated support		NA
156.		Appliances normally fixed to a wall and appliances with pins for insertion into socket-outlets are mounted on a wooden board		NA
157.		For IPX3 appliances, the base of wall mounted appliances is placed at the same level as the pivot axis of the oscillating tube		NA
158.		For IPX4 appliances, the horizontal centre line of the appliance is aligned with the pivot axis of the oscillating tube		P
159.		However, for appliances normally used on the floor or table, the movement is limited to two times 90° for a period of 5 min, the support being placed at the level of the pivot axis of the oscillating tube		NA
160.		Wall-mounted appliances, take into account the distance to the floor stated in the instructions		NA
161.		Appliances normally fixed to a ceiling are mounted underneath a horizontal unperforated support, the pivot axis of the oscillating tube located at the level of the underside of the support and aligned centrally with the appliance.		NA



**LAB RECORDS**  
**FORM 201-4117-TRF-E**

page: 13/85

(Lab Record S/N):

**504231-E**

Seq. No	Paragraphs	Requirements	Results Measurements Remarks	Verdict
162.		For IPX4 appliances, the movement of the tube is limited to two times 90° from the vertical for a period of 5 min		<b>P</b>
163.		Appliances with type X attachment fitted with a flexible cord as described		<b>NA</b>
164.		Detachable parts tested as specified		<b>NA</b>
165.	15.2 (EN 60335-2-21)	The test of 15.2 is only applicable to cistern-type water heater.		<b>NA</b>
166.	15.2	Spillage of liquid does not affect the electrical insulation		<b>NA</b>
167.		Appliances with type X attachment fitted with a flexible cord as described		<b>NA</b>
168.		Appliances incorporating an appliance inlet tested with or without a connector, whichever is most unfavourable		<b>NA</b>
169.		Detachable parts removed		<b>NA</b>
170.		The appliance withstands the electric strength test of 16.3		<b>NA</b>
171.		No trace of water on insulation that can result in a reduction of clearances and creepage distances below values specified in clause 29		<b>NA</b>
172.	15.3	Appliances proof against humid conditions	25°C; 93% R.H.	<b>P</b>
173.		Humidity test for 48 h in a humidity cabinet		<b>P</b>
174.		The appliance withstands the tests of clause 16		<b>P</b>
	<b>16</b>	<b>LEAKAGE CURRENT AND ELECTRIC STRENGTH</b>		
175.	16.1	Leakage current not excessive and electric strength adequate		<b>P</b>
176.		Protective impedance disconnected from live parts before carrying out the tests		<b>NA</b>
177.	16.2	Single-phase appliances: test voltage 1.06 times rated voltage.....:	1,06 x 230 = 243,80 V	<b>P</b>
178.		Three-phase appliances: test voltage 1.06 times rated voltage divided by $\sqrt{3}$ ...		<b>NA</b>
179.		Leakage current measurements	See Table 16.2	<b>P</b>
180.	16.3	Electric strength tests according to table 7	See Table 16.3	<b>P</b>
181.		No breakdown during the tests		<b>P</b>



**LAB RECORDS**  
**FORM 201-4117-TRF-E**

page: 14/85

(Lab Record S/N):

**504231-E**

Seq. No	Paragraphs	Requirements	Results Measurements Remarks	Verdict
	17	<b>OVERLOAD PROTECTION OF TRANSFORMERS AND ASSOCIATED CIRCUITS</b>		
182.		No excessive temperatures in transformer or associated circuits in event of short-circuits likely to occur in normal use		NA
183.		Appliance supplied with 1.06 or 0.94 times rated voltage and the most unfavourable short-circuit or overload likely to occur in normal use applied.....		NA
184.		Temperature rise of insulation of the conductors of safety extra-low voltage circuits not exceeding the relevant value specified in table 3 by more than 15 K		NA
185.		Temperature of the winding not exceeding the value specified in table 8,		NA
186.		however limits do not apply to fail-safe transformers complying with sub-clause 15.5 of IEC 61558-1		NA
	19	<b>ABNORMAL OPERATION</b>		
187.	19.1	The risk of fire or mechanical damage under abnormal or careless operation obviated.		P
188.		Electronic circuits so designed and applied that a fault will not render the appliance unsafe		NA
189.		Appliances incorporating contactors or relays subjected to the test of 19.14, being carried out before the tests of 19.11		NA
190.	19.1 (EN 60335-2-21)	Instead of the tests specified for appliances incorporating heating elements, the following applies:		P
191.	19.1 (EN 60335-2-21)	For closed water heaters, low-pressure water heaters and open-outlet water heaters, compliance is checked by the tests of 19.2, 19.3 and 19.4 if applicable. However, 19.101 applies instead for appliances not liable to be emptied in normal use and having all four of the following features:	The test of 19.101 was performed since requirements 192 to 195 are satisfied.	
192.	19.1 (EN 60335-2-21)	– an outer enclosure of metal;		P



**LAB RECORDS**  
**FORM 201-4117-TRF-E**

page: 15/85

(Lab Record S/N):

**504231-E**

Seq. No	Paragraphs	Requirements	Results Measurements Remarks	Verdict
193.	19.1 (EN 60335-2-21)	– non-combustible thermal insulation;		P
194.	19.1 (EN 60335-2-21)	– a capacity exceeding 30 l;	300 l;	P
195.	19.1 (EN 60335-2-21)	– a rated power input not exceeding 6 kW.	4kW	P
196.	19.2	Test of appliance with heating elements with restricted heat dissipation; test voltage (V).....: power input of 0.85 times rated power input.....:		NA
197.	19.3	Test of 19.2 repeated; test voltage (V).....: power input of 1.24 times rated power input .....		NA
198.	19.4	Test conditions as in cl. 11, any control limiting the temperature during tests of cl. 11 short-circuited		NA
199.	19.4 (EN 60335-2-21)	For open-outlet water heaters, the test of 19.2 is repeated with the container filled with water to a level at least 10 mm above the highest point of the heating element. The appliance is operated at 1,15 times rated power input under normal operation		NA
200.	19.5	Test of 19.4 repeated on Class 0I and I appliances with tubular sheathed or embedded heating elements. No short-circuiting, but one end of the element connected to the elements sheath		NA
201.		The test repeated with reversed polarity and the other end of the heating element connected to the sheath		NA
202.		The test is not carried out on appliances intended to be permanently connected to fixed wiring and on appliances where an all-pole disconnection occurs during the test of 19.4		NA
203.	19.6	Appliances with PTC heating elements tested at rated voltage, establishing steady conditions		NA



**LAB RECORDS**  
**FORM 201-4117-TRF-E**

page: 16/85

**(Lab Record S/N):** **504231-E**

Seq. No	Paragraphs	Requirements	Results Measurements Remarks	Verdict
204.		The working voltage of the PTC heating element is increased by 5% and the appliance is operated until steady conditions are re-established. The voltage is then increased in similar steps until 1.5 times working voltage or until the PTC heating element ruptures.		<b>NA</b>
205.	19.7	Stalling test by locking the rotor if the locked rotor torque is smaller than the full load torque or locking moving parts of other appliances		<b>NA</b>
206.		Locked rotor, motor capacitors open-circuited or short-circuited, if required		<b>NA</b>
207.		Locked rotor, capacitors open-circuited one at a time		<b>NA</b>
208.		Test repeated with capacitors short-circuited one at a time, if required		<b>NA</b>
209.		Appliances with timer or programmer supplied with rated voltage for each of the tests, for a period equal to the maximum period allowed		<b>NA</b>
210.		Other appliances supplied with rated voltage for a period as specified		<b>NA</b>
211.		Winding temperatures not exceeding values specified in table 8		<b>NA</b>
212.	19.8	Three-phase motors operated at rated voltage with one phase disconnected		<b>NA</b>
213.	19.9	Running overload test on appliances incorporating motors intended to be remotely or automatically controlled or liable to be operated continuously		<b>NA</b>
214.		Winding temperatures not exceeding values as specified		<b>NA</b>
215.	19.10	Series motor operated at 1.3 times rated voltage for 1 min.....:		<b>NA</b>
216.		During the test, parts not being ejected from the appliance		<b>NA</b>
217.	19.11	Electronic circuits, compliance checked by evaluation of the fault conditions specified in 19.11.2 for all circuits or parts of circuits, unless		<b>NA</b>
218.		they comply with the conditions specified in 19.11.1		<b>NA</b>
219.		Appliances incorporating an electronic circuit that relies upon a		<b>NA</b>



**LAB RECORDS**  
**FORM 201-4117-TRF-E**

page: 17/85

(Lab Record S/N):

**504231-E**

Seq. No	Paragraphs	Requirements	Results Measurements Remarks	Verdict
		programmable component to function correctly, subjected to the test of 19.11.4.8, unless		
220.		restarting does not result in a hazard		<b>NA</b>
221.		Appliances having a device with an off position obtained by electronic disconnection, or a device placing the appliance in a stand-by mode, subjected to the tests of 19.11.4		<b>NA</b>
222.		If the safety of the appliance under any of the fault conditions depends on the operation of a miniature fuse-link complying with IEC 60127, the test of 19.12 is carried out		<b>NA</b>
		During and after each test, the following is checked:		
223.		- the temperature rise of the windings do not exceed the values specified in table 8		<b>NA</b>
224.		- the appliance complies with the conditions specified in 19.13		<b>NA</b>
225.		- any current flowing through protective impedance not exceeding the limits specified in 8.1.4		<b>NA</b>
		If a conductor of a printed board becomes open-circuited, the appliance is considered to have withstood the particular test, provided both of the following conditions are met:		
226.		- the material of the printed circuit board withstands the burning test of annex E		<b>NA</b>
227.		- any loosened conductor does not reduce the clearances or creepage distances between live parts and accessible metal parts below the values specified in cl. 29		<b>NA</b>
	19.11.1	Fault conditions a) to g) in 19.11.2 are not applied to circuits or parts of circuits meeting both of the following conditions:		
228.		- the electronic circuit is a low-power circuit, that is, the maximum power at low-power points does not exceed 15 W according to the tests specified		<b>NA</b>
229.		- the protection against electric shock, fire hazard, mechanical hazard or dangerous malfunction in other parts of the appliance does not rely on the correct functioning of the electronic circuit		<b>NA</b>



**LAB RECORDS**  
**FORM 201-4117-TRF-E**

page: 18/85

(Lab Record S/N):

**504231-E**

Seq. No	Paragraphs	Requirements	Results Measurements Remarks	Verdict
	19.11.2	Fault conditions applied one at a time, the appliance operated under conditions specified in cl. 11, but supplied at rated voltage, the duration of the tests as specified:		
230.		a) short circuit of functional insulation if clearances or creepage distances are less than the values specified in 29		NA
231.		b) open circuit at the terminals of any component		NA
232.		c) short circuit of capacitors, unless they comply with IEC 60384-14		NA
233.		d) short circuit of any two terminals of an electronic component, other than integrated circuits. This fault condition is not applied between the two circuits of an optocoupler		NA
234.		e) failure of triacs in the diode mode		NA
235.		f) failure of an integrated circuit		NA
236.		g) failure of an electronic power switching device in a partial turn-on mode with loss of gate (base) control.		NA
237.		Each low power circuit is short-circuited by connecting the low-power point to the pole of the supply source from which the measurements were made		NA
238.	19.11.3	If the appliance incorporates a protective electronic circuit which operates to ensure compliance with clause 19, the relevant test is repeated with a single fault simulated, as indicated in a) to f) of 19.11.2		NA
239.	19.11.4	Appliances having a device with an off position obtained by electronic disconnection, or		NA
240.		a device that can be placed in the stand-by mode,		NA
241.		subjected to the tests of 19.11.4.1 to 19.11.4.7, the device being set in the off position or in the stand-by mode.		NA
242.		Appliances incorporating a protective electronic circuit subjected to the tests of 19.11.4.1 to 19.11.4.7, except that		NA
243.		appliances operated for 30 s or 5 min during the test of 19.7 are not subjected to the tests for electromagnetic phenomena.		NA



**LAB RECORDS**  
**FORM 201-4117-TRF-E**

page: 19/85

(Lab Record S/N):

**504231-E**

Seq. No	Paragraphs	Requirements	Results Measurements Remarks	Verdict
244.		Surge protective devices disconnected, unless		NA
245.		They incorporate spark gaps		NA
246.	19.11.4.1	The appliance is subjected to electrostatic discharges in accordance with IEC 61000-4-2, test level 4		NA
247.	19.11.4.2	The appliance is subjected to radiated fields in accordance with IEC 61000-4-3, test level 3		NA
248.	19.11.4.3	The appliance is subjected to fast transient bursts in accordance with IEC 61000-4-4, test level 3 or 4 as specified		NA
249.	19.11.4.4	The power supply terminals of the appliance subjected to voltage surges in accordance with IEC 61000-4-5, test level 3 or 4 as specified		NA
250.		Earthed heating elements in class I appliances disconnected		NA
251.	19.11.4.5	The appliance is subjected to injected currents in accordance with IEC 61000-4-6, test level 3		NA
252.	19.11.4.6	For appliances having a rated current not exceeding 16 A ,the appliance is subjected to the Class 3 voltage dips and interruptions in accordance with IEC 61000-4-11		NA
253.		For appliances having a rated current exceeding 16 A ,the appliance is subjected to the Class 3 voltage dips and interruptions in accordance with IEC 61000-4-34		NA
254.	19.11.4.7	The appliance is subjected to mains signals in accordance with IEC 61000-4-13, test level class 2		NA
255.	19.11.4.8	The appliance is supplied at rated voltage and operated under normal operation. After 60s the power supply is reduces to a level such that the appliance ceases to respond or a programmable component cease to operate.		NA
256.		The appliance continues to operate normally or		NA
257.		requires a manual operation to restart		NA
258.	19.12	If the safety of the appliance for any of the fault conditions specified in		NA



**LAB RECORDS**  
**FORM 201-4117-TRF-E**

page: 20/85

(Lab Record S/N):

**504231-E**

Seq. No	Paragraphs	Requirements	Results Measurements Remarks	Verdict
		19.11.2 depends on the operation of a miniature fuse-link complying with IEC 60127, the test is repeated, measuring the current flowing through the fuse-link; measured current (A); rated current of the fuse-link (A).....:		
259.	19.13	During the tests the appliance does not emit flames, molten metal, poisonous or ignitable gas in hazardous amounts		<b>P</b>
260.		Temperature rises not exceeding the values shown in table 9.....:	(see appended table)	<b>P</b>
261.		Compliance with clause 8 not impaired		<b>P</b>
262.		If the appliance can still be operated it complies with 20.2		<b>P</b>
		Insulation, other than of class III appliance, withstand the electric strength test of 16.3, the test voltage specified in table 4:		
263.		- basic insulation .....	1000 V	<b>P</b>
264.		- supplementary insulation.....:		<b>NA</b>
265.		- reinforced insulation.....:	3000 V	<b>P</b>
266.		After operation or interruption of a control, clearances and creepage distances across the functional insulation withstanding the electric strength test of 16.3. the test voltage being twice the working voltage		<b>P</b>
267.		The appliance does not undergo a dangerous malfunction, and		<b>P</b>
268.		no failure of protective electronic circuits, if the appliance is still operable		<b>P</b>
		Appliances tested with an electronic switch in the off position or in the stand-by mode:		
269.		- do not become operational, or		<b>NA</b>
270.		- if they become operational, do not result in a dangerous malfunction during or after the tests of 19.11.4		<b>NA</b>
271.		If the appliance contains lids or doors that are controlled by one or more interlocks, one of the interlocks may be released provided that:		<b>NA</b>
272.		- the lid or door does not move automatically to an open position when the interlock is released, and		<b>NA</b>



**LAB RECORDS**  
**FORM 201-4117-TRF-E**

page: 21/85

(Lab Record S/N):

**504231-E**

Seq. No	Paragraphs	Requirements	Results Measurements Remarks	Verdict
273.		- the appliance does not start after the cycle in which the interlock was released		NA
274.	19.13 (EN 60335-2-21)	There shall be no leakage from the container during the tests.		P
275.	19.14	Appliances operated under the conditions of Clause 11. Contactors or relays contacts operating under the conditions of clause 11 short-circuited		NA
276.		If a relay or contactor with more than one contact is used, all contacts are short-circuited at the same time.		NA
277.		Any relay or contactor which operates only in order to ensure that the appliance is energized for normal use and that does not otherwise operate in normal use is not short-circuited.		NA
278.		If more than one relay or contactor operates in Clause 11, each such relay or contactor is short-circuited in turn.		NA
279.		For appliances incorporating a mains voltage selector switch, this switch is set to the lowest rated voltage position and the highest value of rated voltage is applied.		NA
280.	19.15	For appliances incorporating a mains voltage selector switch, this switch is set to the lowest rated voltage position and the highest value of rated voltage is applied.		NA
281.	19.101 (EN 60335-2-21)	The appliance is tested for 24 h under the conditions specified in Clause 11 but with the container empty.		P
	<b>20</b>	<b>STABILITY AND MECHANICAL HAZARDS</b>		
282.	20.1	Adequate stability		NA
283.		Tilting test through an angle of 10° (appliance placed on an inclined plane/horizontal plane); appliance does not overturn		NA
284.		Tilting test repeated on appliances with heating elements, angle of inclination increased to 15°		NA
285.		Possible heating test in overturned position; temperature rise does not exceed values shown in table 9		NA



**LAB RECORDS**  
**FORM 201-4117-TRF-E**

page: 22/85

(Lab Record S/N):

**504231-E**

Seq. No	Paragraphs	Requirements	Results Measurements Remarks	Verdict
286.	20.2	Moving parts adequately arranged or enclosed as to provide protection against personal injury		NA
287.		Protective enclosures, guards and similar parts are non-detachable		NA
288.		Adequate mechanical strength and fixing of protective enclosures		NA
289.		Self-resetting thermal cut-outs and overcurrent protective devices not causing a hazard, by unexpected reclosure		NA
290.		Not possible to touch dangerous moving parts with test probe		NA
	<b>21</b>	<b>MECHANICAL STRENGTH</b>		
291.	21.1	Appliance has adequate mechanical strength and is constructed as to withstand rough handling		P
292.		Checked by applying blows to the appliance in accordance with test Ehb of IEC 60068-2-75, spring hammer test, impact energy 0,5 J		P
293.		The appliance shows no damage impairing compliance with this standard, and		P
294.		compliance with 8.1, 15.1 and clause 29 not impaired		P
295.		If doubt, supplementary or reinforced insulation subjected to the electric strength test of 16.3		NA
296.		If necessary, repetition of groups of three blows on a new sample		NA
297.	21.2	Accessible parts of solid insulation having strength to prevent penetration by sharp implements		NA
298.		Test not applicable if the thickness of supplementary insulation is at least 1 mm and reinforced insulation at least 2 mm		P
299.		The insulation is tested as specified, and does withstand the electric strength test of 16.3		NA
	<b>22</b>	<b>CONSTRUCTION</b>		
300.	22.1	Appliance marked with the first numeral of the IP system, relevant requirements of IEC 60529 are fulfilled	IP24	P
	22.2	Stationary appliance: means to provide all-pole disconnection from		



**LAB RECORDS**  
**FORM 201-4117-TRF-E**

page: 23/85

(Lab Record S/N):

**504231-E**

Seq. No	Paragraphs	Requirements	Results Measurements Remarks	Verdict
		the supply provided, the following means being available:		
301.		- a supply cord fitted with a plug		NA
302.		- a switch complying with 24.3		NA
303.		- a statement in the instruction sheet that a disconnection incorporated in the fixed wiring is to be provided		NA
304.		- an appliance inlet		NA
305.		Single-pole switches and single-pole protective devices for the disconnection of heating elements in single-phase permanently connected class I appliances, connected in the phase conductor		NA
306.	22.3	Appliance provided with pins: no undue strain on socket-outlets		NA
307.		Applied torque not exceeding 0.25 Nm		NA
308.		Pull force of 50N to each pin after the appliance has being placed in the heating cabinet; when cooled to room temperature the pins are not displaced by more than 1mm		NA
309.		Each pin subjected to a torque of 0.4Nm; the pins are not rotating unless		NA
310.		rotating does not impair compliance with this standard		NA
311.	22.4	Appliance for heating liquids and appliance causing undue vibration not provided with pins for insertion into socket-outlets		P
312.	22.5	No risk of electric shock when touching the pins of the plug, for appliances having a capacitor with rated capacitance exceeding 0,1 μF, the appliance being disconnected from the supply at the instant of voltage peak.		NA
313.		Voltage not exceeding 34 V (V).....:		NA
314.	22.6	Electrical insulation not affected by condensing water or leaking liquid		P
315.		Electrical insulation of Class II appliances not affected in case of a hose rupture or seal leak		NA
316.		In case of doubt, test as described		NA
317.	22.6 (EN 60335-2-21)	condensed water cannot accumulate within the enclosure		P



**LAB RECORDS**  
**FORM 201-4117-TRF-E**

page: 24/85

(Lab Record S/N):

**504231-E**

Seq. No	Paragraphs	Requirements	Results Measurements Remarks	Verdict
318.	22.6 (EN 60335-2-21)	The enclosure shall have a drain hole positioned so that the water can drain without impairing electrical insulation		NA
319.	22.6 (EN 60335-2-21)	The hole shall be at least 5 mm in diameter or 20 mm <sup>2</sup> in area with a width of at least 3 mm		NA
320.	22.7	Adequate safeguards against the risk of excessive pressure in appliances provided with steam-producing devices		NA
321.	22.8	Electrical connections not subject to pulling during cleaning of compartments to which access can be gained without the aid of a tool, and that are likely to be cleaned in normal use		NA
322.	22.9	Insulation, internal wiring, windings, commutators and slip rings not exposed to oil, grease or similar substances, unless		P
323.		the substance has adequate insulating properties		NA
324.	22.10	Not possible to reset voltage-maintained non-self-resetting thermal cut-outs by the operation of an automatic switching device incorporated within the appliance, if:		NA
325.		- a non-self-resetting thermal cut-out is required by the standard, and		NA
326.		- a voltage maintained non-self-resetting thermal cut-out is used to meet it		NA
327.		Non-self resetting thermal motor protectors have a trip-free action, unless		NA
328.		they are voltage maintained		NA
329.		Reset buttons of non-self-resetting controls so located or protected that accidental resetting is unlikely		NA
330.	22.11	Reliable fixing of non-detachable parts that provide the necessary degree of protection against electric shock, moisture or contact with moving parts		P
331.		Obvious locked position of snap-in devices used for fixing such parts		NA
332.		No deterioration of the fixing properties of snap-in devices used in parts that are likely to be removed		NA



**LAB RECORDS**  
**FORM 201-4117-TRF-E**

page: 25/85

(Lab Record S/N):

**504231-E**

Seq. No	Paragraphs	Requirements	Results Measurements Remarks	Verdict
		during installation or servicing		
333.		Tests as described	Pull=Push 50 N Torque=2Nm (gland)	P
334.	22.12	Handles, knobs etc. fixed in a reliable manner		NA
335.		Fixing in wrong position of handles, knobs etc. indicating position of switches or similar components not possible		NA
336.		Axial force 15 N applied to parts, the shape being so that an axial pull is unlikely to be applied		NA
337.		Axial force 30 N applied to parts, the shape being so that an axial pull is likely to be applied		NA
338.	22.13	Unlikely that handles, when gripped as in normal use, make the operators hand touch parts having a temperature rise exceeding the value specified for handles which are held for short periods only		NA
339.	22.14	No ragged or sharp edges creating a hazard for the user in normal use, or during user maintenance		P
340.		No exposed pointed ends of self tapping screws etc., liable to be touched by the user in normal use or during user maintenance		NA
341.	22.15	Storage hooks and the like for flexible cords smooth and well rounded		NA
342.	22.16	Automatic cord reels cause no undue abrasion or damage to the sheath of the flexible cord, no breakage of conductors strands, no undue wear of contacts		NA
343.		Cord reel tested with 6000 operations, as specified		NA
344.		Electric strength test of 16.3, voltage of 1000 V applied		NA
345.	22.17	Spacers not removable from the outside by hand or by means of a screwdriver or a spanner		NA
346.	22.18	Current-carrying parts and other metal parts resistant to corrosion under normal conditions of use		P
347.	22.19	Driving belts not used as electrical insulation		NA



**LAB RECORDS**  
**FORM 201-4117-TRF-E**

page: 26/85

(Lab Record S/N):

**504231-E**

Seq. No	Paragraphs	Requirements	Results Measurements Remarks	Verdict
348.	22.20	Direct contact between live parts and thermal insulation effectively prevented, unless		P
349.		material used is non-corrosive, non-hygroscopic and non-combustible		NA
350.	22.20 (EN 60335-2-21)	Thermal insulation shall not be used for basic insulation of internal wiring		P
351.	22.21	Wood, cotton, silk, ordinary paper and fibrous or hygroscopic material not used as insulation, unless		P
352.		impregnated		NA
353.		This requirement does not apply to magnesium oxide and mineral ceramic fibres used for the electrical insulation of heating elements		NA
354.	22.22	Appliances not containing asbestos		P
355.	22.23	Oils containing polychlorinated biphenyl (PCB) not used		P
356.	22.24	Bare heating elements, except in class III appliances or class III constructions that do not contain live parts, adequately supported.		NA
357.		In case of rupture, the heating conductor is unlikely to come in contact with accessible metal parts		P
358.	22.25	Sagging heating conductors, except in class III appliances or class III constructions that do not contain live parts, cannot come into contact with accessible metal parts.		NA
359.	22.26	For class III constructions the insulation between parts operating at safety extra-low voltage and other live parts complies with the requirements for double or reinforced insulation		NA
360.	22.27	Parts connected by protective impedance separated by double or reinforced insulation		NA
361.	22.28	Metal parts of Class II appliances conductively connected to gas pipes or in contact with water: separated from live parts by double or reinforced insulation		NA
362.	22.29	Class II appliances permanently connected to fixed wiring so constructed that the required degree of access to live parts is maintained		NA



**LAB RECORDS**  
**FORM 201-4117-TRF-E**

page: 27/85

(Lab Record S/N):

**504231-E**

Seq. No	Paragraphs	Requirements	Results Measurements Remarks	Verdict
		after installation		
363.	22.30	Parts serving as supplementary or reinforced insulation fixed so that they cannot be removed without being seriously damaged, or		P
364.		so constructed that they cannot be replaced in an incorrect position, and so that if they are omitted, the appliance is rendered inoperable or manifestly incomplete		P
365.	22.31	Clearances and creepage distances over supplementary and reinforced insulation not reduced below values specified in clause 29 as a result of wear		P
366.		Clearances and creepage distances between live parts and accessible parts not reduced below values for supplementary insulation, if wires, screws etc. become loose		NA
367.	22.32	Supplementary and reinforced insulation designed or protected against pollution so that clearances or creepage distances are not reduced below the values in clause 29.		P
368.		Supplementary insulation of natural or synthetic rubber resistant to ageing, or arranged and dimensioned so that creepage distances are not reduced below values specified in 29.2		NA
369.		Ceramic material not tightly sintered, similar material or beads alone not used as supplementary or reinforced insulation		NA
370.		Oxygen bomb test at 70 °C for 96 h and 16 h at room temperature		NA
371.		Insulating material in which heating conductors are embedded is considered to be basic insulation and not reinforced insulation		P
372.		Oxygen bomb test at 70°C for 96 h and 16 h at room temperature.		NA
373.	22.33	Conductive liquids that are or may become accessible in normal use are not in direct contact with live parts		P
374.		Electrodes not used for heating liquids		P
375.		For class II constructions, conductive liquids that are or may become accessible in normal use, not in direct		NA



**LAB RECORDS**  
**FORM 201-4117-TRF-E**

page: 28/85

(Lab Record S/N):

**504231-E**

Seq. No	Paragraphs	Requirements	Results Measurements Remarks	Verdict
		contact with basic or reinforced insulation, unless		
376.		the reinforced insulation consists of at least 3 layers.		NA
377.		For class II constructions, conductive liquids which are in contact with live parts, not in direct contact with reinforced insulation, unless		NA
378.		the reinforced insulation consists of at least 3 layers.		NA
379.		An air layer not used as basic or supplementary insulation in a double insulation system if likely to be bridged by leaking liquid		NA
380.	22.34	Shafts of operating knobs, handles, levers etc. not live, unless		NA
381.		the shaft is not accessible when the part is removed		
382.	22.35	For other than class III constructions, handles, levers and knobs, held or actuated in normal use, not becoming live in the event of a failure of basic insulation.		NA
383.		Such parts being of metal, and their shafts or fixings are likely to become live in the event of a failure of basic insulation, are either adequately covered by insulation material or their accessible parts are separated from their shafts or fixings by supplementary insulation		NA
384.		This requirement does not apply to handles, levers and knobs on stationary appliances other than those of electrical components, provided they are either reliably connected to an earthing terminal or earthing contact, or separated from live parts by earthed metal		NA
385.		Insulating material covering metal handles, levers and knobs withstand the electric strength test of 16.3 for supplementary insulation.		NA
386.	22.36	For appliances other than class III handles continuously held in the hand in normal use are so constructed that when gripped as in normal use, the operators hand is not likely to touch metal parts, unless		NA



**LAB RECORDS**  
**FORM 201-4117-TRF-E**

page: 29/85

**(Lab Record S/N): 504231-E**

Seq. No	Paragraphs	Requirements	Results Measurements Remarks	Verdict
387.		they are separated from live parts by double or reinforced insulation		NA
388.	22.37	Capacitors in Class II appliances not connected to accessible metal parts and their casings, if of metal, separated from accessible metal parts by supplementary insulation, unless		NA
389.		the capacitors comply with 22.42		NA
390.	22.38	Capacitors not connected between the contacts of a thermal cut-out		P
391.	22.39	Lamp holders used only for the connection of lamps		NA
392.	22.40	Motor-operated appliances and combined appliances intended to be moved while in operation, or having accessible moving parts, fitted with a switch to control the motor. The actuating member of the switch being easily visible and accessible		NA
393.		Unless the appliance can operate continuously, automatically or remotely without giving rise to a hazard, appliances for remote operation being fitted with a switch. The actuating member of the switch being easily visible and accessible.		NA
394.	22.41	No components, other than lamps, containing mercury.		P
395.	22.42	Protective impedance consisting of at least two separate components		NA
396.		Values specified in 8.1.4 not exceeded if any one of the components are short-circuited or open-circuited		NA
397.		Resistors checked by the test of 14.1 a) in IEC 60065		NA
398.		Capacitors checked by the tests for class Y capacitors in IEC 60384-14		NA
399.	22.43	Appliances adjustable for different voltages, accidental changing of the setting of the voltage unlikely to occur		NA
400.	22.44	Appliances shall not have an enclosure that is shaped or decorated like a toy		P
401.	22.45	When air is used as reinforced insulation, clearances not reduced below the values specified in 29.1.3 due to deformation as a result of an external force applied to the enclosure		NA



**LAB RECORDS**  
**FORM 201-4117-TRF-E**

page: 30/85

(Lab Record S/N):

**504231-E**

Seq. No	Paragraphs	Requirements	Results Measurements Remarks	Verdict
402.	22.46	For programmable protective electronic circuits used to ensure compliance with this standard, the software shall contain measures to control the fault/error conditions specified in Table R.1.		NA
403.		Software that contains measures to control the fault/error conditions specified in Table R.2 is to be specified in parts 2 for particular constructions or to address specific hazards.		NA
404.		These requirements are not applicable to software used for functional purpose or compliance with clause 11		NA
405.	22.47 (EN 60335-2-21)	Appliances shall withstand the water pressure occurring in normal use		P
		Compliance is checked by subjecting the appliance to a water pressure of		
406.		– twice the rated pressure, for closed water heaters. If the water heater is supplied through a pressure reducing valve, the container is subjected to twice the working pressure instead	2 MPa	P
407.		– 1,5 times rated pressure, for cistern-fed water heaters and low-pressure water heaters;		NA
408.		– 0,15 MPa, for open-outlet water heaters;		NA
409.		– 0,03 MPa, for cistern-type water heaters.		NA
410.		Pressure-relief devices are rendered inoperative. The pressure is raised at a rate of 0,13 MPa/s to the specified value and is maintained at that value for 15 min.		P
411.		Water shall not leak from the appliance and there shall be no permanent deformation to such an extent that compliance with this standard is impaired		P
412.	22.48	Appliances connected to the water mains constructed to prevent backsiphonage of non-potable water		P
413.	22.49	For remote operation, the duration of operation shall be set before the appliance can be started, unless		NA



**LAB RECORDS**  
**FORM 201-4117-TRF-E**

page: 31/85

(Lab Record S/N):

**504231-E**

Seq. No	Paragraphs	Requirements	Results Measurements Remarks	Verdict
414.		the appliance switches off automatically or can operate continuously without hazard		NA
415.	22.50	Controls incorporated in the appliance take priority over controls actuated by remote operation		NA
416.	22.51	A control on the appliance being manually adjusted to the setting for remote operation before the appliance can be operated in this mode		NA
417.		There is a visual indication showing that the appliance is adjusted for remote operation		NA
		These requirements not necessary on appliances that can operate as follows, without giving rise to a hazard:		
418.		- operate continuously,		NA
419.		- operate automatically, or		NA
420.		- be operated remotely		NA
421.	22.52	Socket-outlets on appliances accessible to the user in accordance with the socket-outlet system used in the country in which the appliance is sold		NA
422.	22.101 (EN 60335-2-21)	The rated pressure of closed water heaters intended for direct connection to the water main shall be at least 0,6 MPa	1 MPa	P
423.	22.101 (EN 60335-2-21)	The rated pressure of closed water heaters and low-pressure water heaters, intended to be supplied by a pressure reducing valve that is not incorporated in the appliance, shall be at least 0,1 MPa		NA
424.	22.101 (EN 60335-2-21)	The rated pressure of cistern-fed water heaters shall not exceed 0,2 MPa		NA
425.	22.103 (EN 60335-2-21)	Pressure-relief devices of closed water heaters shall prevent the pressure in the container from exceeding the rated pressure by more than 0,1 MPa		P
426.	22.104 (EN 60335-2-21)	The outlet of open-outlet water heaters shall be constructed so that the water flow is not limited to such an extent that the container is subjected to a significant pressure		NA
427.	22.104 (EN 60335-2-21)	The vent pipe of low pressure water heaters shall have an internal diameter of at least 20 mm.		NA



**LAB RECORDS**  
**FORM 201-4117-TRF-E**

page: 32/85

(Lab Record S/N):

**504231-E**

Seq. No	Paragraphs	Requirements	Results Measurements Remarks	Verdict
428.	22.105 (EN 60335-2-21)	Cistern-type water heaters shall be constructed so that the container is always at atmospheric pressure by means of a vent having an area of at least 30 mm <sup>2</sup> and a minimum dimension of at least 3mm		NA
429.	22.106 (EN 60335-2-21)	Closed water heaters shall incorporate a thermal cut-out providing all-pole disconnection and which operates independently from the thermostat. However, for appliances intended to be connected to fixed wiring, the neutral conductor need not be disconnected	Incorporated device that works as a thermostat and a thermal cut-out.	P
430.	22.107 (EN 60335-2-21)	Heating elements and thermal control sensors in contact with the outer surface of the container shall be held in position securely.		P
431.	22.108 (EN 60335-2-21)	Appliances for wall mounting shall have reliable provision for fixing to a wall, independent of the connection to the water mains		NA
432.	22.109 (EN 60335-2-21)	Appliances having a capacity of more than 15 l that cannot be emptied through a drain fitted in the water pipes shall incorporate means for draining that requires a tool for its operation		NA
433.	22.110 (EN 60335-2-21)	Open-outlet water heaters having plastic containers shall be constructed to ensure that the appliance is only likely to be installed in the intended orientation.		NA
434.	22.111 (EN 60335-2-21)	Closed water heaters incorporating a heat exchanger shall be constructed so that during normal use the thermal cut-out does not operate due to heat from the exchanger		NA
435.	22.111 (EN 60335-2-21)	Thermostatic valves, by-pass valves and similar controlling devices used for this purpose shall be supplied with the appliance		NA
436.	22.112 (EN 60335-2-21)	Closed water heaters shall be constructed so that repeated drawing off does not cause the water to boil		P



**LAB RECORDS**  
**FORM 201-4117-TRF-E**

page: 33/85

(Lab Record S/N):

**504231-E**

Seq. No	Paragraphs	Requirements	Results Measurements Remarks	Verdict
	23	<b>INTERNAL WIRING</b>		-
437.	23.1	Wire ways smooth and free from sharp edges		P
438.		Wires protected against contact with burrs, cooling fins etc.		P
439.		Wire holes in metal well rounded or provided with bushings		NA
440.		Wiring effectively prevented from coming into contact with moving parts		NA
441.	23.2	Beads etc. on live wires cannot change their position, and are not resting on sharp edges or corners		NA
442.		Beads inside flexible metal conduits contained within an insulating sleeve		NA
443.	23.3	Electrical connections and internal conductors movable relatively to each other not exposed to undue stress		NA
444.		Flexible metallic tubes not causing damage to insulation of conductors		NA
445.		Open-coil springs not used		NA
446.		Adequate insulating lining provided inside a coiled spring, the turns of which touch one another		NA
447.		No damage after 10 000 flexings for conductors flexed during normal use or		NA
448.		100 flexings for conductors flexed during user maintenance		NA
449.		Electric strength test, 1000 V between live parts and accessible metal parts		NA
450.		Not more than 10% of the strands of any conductor broken, and		NA
451.		not more than 30% for wiring supplying circuits that consume no more than 15W.		NA
452.	23.4	Bare internal wiring sufficiently rigid and fixed		NA
453.	23.5	The insulation of internal wiring withstanding the electrical stress likely to occur in normal use		P
454.		Basic insulation electrically equivalent to the basic insulation of cords complying with IEC 60227 or IEC 60245, or		NA



**LAB RECORDS**  
**FORM 201-4117-TRF-E**

page: 34/85

**(Lab Record S/N): 504231-E**

Seq. No	Paragraphs	Requirements	Results Measurements Remarks	Verdict
455.		no breakdown when a voltage of 2000 V is applied for 15 min between the conductor and metal foil wrapped around the insulation		<b>P</b>
456.	23.6	Sleeving used as supplementary insulation on internal wiring retained in position by positive means or		<b>NA</b>
457.		be such that it can only be removed by breaking or cutting		<b>NA</b>
458.	23.7	The colour combination green/yellow used only for earthing conductors		<b>P</b>
459.	23.8	Aluminium wires not used for internal wiring	No Aluminium wire used	<b>NA</b>
460.	23.9	No lead-tin soldering of stranded conductors where they are subject to contact pressure, unless		<b>NA</b>
461.		the contact pressure is provided by spring terminals.		<b>NA</b>
462.	23.10	The insulation and sheath of internal wiring, incorporated in external hoses for the connection of an appliance to the water mains, at least equivalent to that of light polyvinyl chloride sheathed flexible cord (60227 IEC 52)		<b>NA</b>
	<b>24</b>	<b>COMPONENTS</b>		
463.	24.1	Components comply with safety requirements in relevant IEC standards		<b>P</b>
464.		List of components	(see appended table 24.1)	<b>P</b>
465.		Components not tested and found to comply with relevant IEC standard for the number of cycles specified are tested in accordance with 24.1.1 to 24.1.9		<b>P</b>
466.		For components mentioned in 24.1.1 to 24.1.9 no additional tests specified in the relevant component standard are necessary other than those specified in 24.1.1 to 24.1.9		<b>P</b>
467.		Components not tested and found to comply with relevant IEC standard, components not marked or not used in accordance with its marking, tested under the conditions occurring in the appliance		<b>NA</b>



**LAB RECORDS**  
**FORM 201-4117-TRF-E**

page: 35/85

(Lab Record S/N):

**504231-E**

Seq. No	Paragraphs	Requirements	Results Measurements Remarks	Verdict
468.		Lampholders and starterholders that have not being tested and found to comply with the relevant IEC standard, tested as a part of the appliance and additionally according to the gauging and interchangeability requirements of the relevant IEC standard		<b>NA</b>
469.		No additional tests specified for nationally standardized plugs such as those detailed in IEC/TR 60083 or connectors complying with the standard sheets of IEC 60320-1 and IEC 60309		<b>NA</b>
470.	24.1.1	Capacitors likely to be permanently subjected to the supply voltage and used for radio interference suppression or for voltage dividing, complying with IEC 60384-14, or		<b>NA</b>
471.		tested according to annex F		<b>NA</b>
472.	24.1.2	Safety isolating transformers complying with IEC 61558-2-6, or		<b>NA</b>
473.		tested according to annex G		<b>NA</b>
474.	24.1.3	Switches complying with IEC 61058-1, the number of cycles of operation being at least 10 000, or		<b>NA</b>
475.		tested according to annex H		<b>NA</b>
476.		If the switch operates a relay or contactor, the complete switching system is subjected to the test		<b>NA</b>
477.		If the switch only operates a motor starting relay complying with IEC 60730-2-10 with the number of cycles of a least 10 000 as specified, the complete switching system need not be tested.		<b>NA</b>
	24.1.4	Automatic controls complying with IEC 60730-1 with relevant part 2. The number of cycles of operation being:		
478.		- thermostats: 10 000		<b>P</b>
479.		- temperature limiters: 1 000		<b>NA</b>
480.		- self-resetting thermal cut-outs: 300		<b>NA</b>
481.		- voltage maintained non-self-resetting thermal cut-outs: 1000		<b>NA</b>
482.		- other non-self-resetting thermal cut-outs: 30		<b>P</b>
483.		- timers: 3 000		<b>NA</b>
484.		- energy regulators: 10 000		<b>NA</b>



**LAB RECORDS**  
**FORM 201-4117-TRF-E**

page: 36/85

(Lab Record S/N):

**504231-E**

Seq. No	Paragraphs	Requirements	Results Measurements Remarks	Verdict
485.		The number of cycles for controls operating during clause 11 need not be declared, if the appliance meets the requirements of this standard when they are short-circuited		<b>NA</b>
486.		Thermal motor protectors are tested in combination with their motor under the conditions specified in Annex D		<b>NA</b>
487.		For water valves containing live parts and that are incorporated in external hoses for connection of an appliance to the water mains, the degree of protection declared for subclause 6.5.2 of IEC 607302-8 is IPX7		<b>NA</b>
488.	24.1.4 (EN 60335-2-21)	Thermal cut-outs incorporated in closed water heaters shall comply with the requirements for type 2B controls in Clauses 13, 15, 16 17 and 20 of IEC 60730-1, unless they are tested with the appliance.		<b>P</b>
489.	24.1.5	Appliance couplers complying with IEC 60320-1		<b>NA</b>
490.		However, appliances classified higher than IPX0, the appliance couplers complying with IEC 60320-2-3		<b>NA</b>
491.		Interconnection couplers complying with IEC 603202-2		<b>NA</b>
492.	24.1.6	Small lamp holders similar to E10 lampholders complying with IEC 60238, the requirements for E10 lampholders being applicable		<b>NA</b>
493.	24.1.7	If the remote operation of the appliance is via a telecommunication network, the relevant standard for the telecommunication interface circuitry in the appliance is IEC 62151		<b>NA</b>
494.	24.1.8	The relevant standard for thermal links is IEC 60691. Thermal links not complying with IEC 60691 are considered to be an intentionally weak part for the purposes of Clause 19		<b>NA</b>
495.		Thermal links not complying with IEC 60691 are considered to be an intentionally weak part for the purposes of Clause 19		<b>NA</b>
496.	24.1.9	Contactors and relays, other than motor starting relays, tested as part of the appliance.		<b>NA</b>



**LAB RECORDS**  
**FORM 201-4117-TRF-E**

page: 37/85

(Lab Record S/N):

**504231-E**

Seq. No	Paragraphs	Requirements	Results Measurements Remarks	Verdict
497.		They are also tested in accordance with Clause 17 of IEC 60730-1, the number of operations in 24.1.4 selected according to the relay function in the appliance.....:		<b>NA</b>
	24.2	Appliances not fitted with:		
498.		-switches or automatic controls in flexible cords		<b>NA</b>
499.		- devices causing the protective device in the fixed wiring to operate in the event of a fault in the appliance		<b>P</b>
500.		-thermal cut-outs that can be reset by soldering, unless		<b>P</b>
501.		the solder has a melting point of at least 230 °C		<b>NA</b>
502.	24.3	Switches intended for all-pole disconnection of stationary appliances are directly connected to the supply terminals and having a contact separation in all poles, providing full disconnection under overvoltage category III conditions		<b>NA</b>
503.	24.4	Plugs and socket-outlets for extra-low voltage circuits and heating elements, not interchangeable with plugs and socket-outlets listed in IEC 60083 or IEC 609061 or with connectors and appliance inlets complying with the standard sheets of IEC 60320-1		<b>NA</b>
504.	24.5	Capacitors in auxiliary windings of motors marked with their rated voltage and capacitance and used accordingly		<b>NA</b>
505.		Voltage across capacitors in series with a motor winding does not exceed 1,1 times rated voltage, when the appliance is supplied at 1,1 times rated voltage under minimum load		<b>NA</b>
506.	24.6	Working voltage of motors connected to the supply mains and having basic insulation that is inadequate for the rated voltage of the appliance, not exceeding 42V.		<b>NA</b>
507.		In addition, the motors are complying with the requirements of Annex I		<b>NA</b>



**LAB RECORDS**  
**FORM 201-4117-TRF-E**

page: 38/85

(Lab Record S/N):

**504231-E**

Seq. No	Paragraphs	Requirements	Results Measurements Remarks	Verdict
508.	24.7	Hose-sets for connection of appliances to the water mains, complying with IEC 61770		NA
509.		They are supplied with the appliance		NA
510.		Appliances intended to be permanently connected to the water mains not connected by a detachable hose-set		P
511.	24.101 (EN 60335-2-21)	Thermal cut-outs shall be non-self-resetting. They shall have a trip-free switching mechanism or be located so that they can only be reset after removal of a non-detachable cover.		P
512.	24.102 (EN 60335-2-21)	The operating temperature of the thermal cut-out of a closed water heater shall ensure that the water temperature cannot exceed 99 °C or that the thermal cut-out operates before its temperature exceeds 110°C.		P
513.	24.102.1 (EN 60335-2-21)	Tested as specified. Water temperature not exceeding 99°C		P
514.	24.102.2 (EN 60335-2-21)	Tested as specified. The thermal cut-out shall operate before its temperature exceeds 110°C. The water temperature shall not exceed 20K of the maximum permitted operating temperature of the thermal cut-out.		NA
515.	<b>25</b>	<b>SUPPLY CONNECTION AND EXTERNAL FLEXIBLE CORDS</b>		
	25.1	Appliance not intended for permanent connection to fixed wiring, means for connection to the supply:		
516.		- supply cord fitted with a plug		NA
517.		- an appliance inlet having at least the same degree of protection against moisture as required for the appliance or		NA
518.		- pins for insertion into socket-outlets		NA
519.	25.1 (EN 60335-2-21)	Appliances shall not incorporate an appliance inlet.		P
520.	25.2	Appliance not provided with more than one means of connection to the supply mains		P



**LAB RECORDS**  
**FORM 201-4117-TRF-E**

page: 39/85

(Lab Record S/N):

**504231-E**

Seq. No	Paragraphs	Requirements	Results Measurements Remarks	Verdict
521.		Stationary appliance for multiple supply may be provided with more than one means of connection, provided electric strength test of 1250 V for 1 min between each means of connection causes no breakdown.		<b>NA</b>
	25.3	Appliance intended to be permanently connected to fixed wiring provided with one of the following means for connection to the supply mains:		
522.		- a set of terminals allowing the connection of a flexible cord		<b>P</b>
523.		- a fitted supply cord		<b>NA</b>
524.		- a set of supply leads accommodated in a suitable compartment		<b>NA</b>
525.		- a set of terminals for the connection of cables of fixed wiring, cross-sectional areas specified in 26.6, and the appliance allows the connection of the supply conductors after the appliance has been fixed to its support		<b>P</b>
526.		- a set of terminals and cable entries, conduit entries, knock-outs or glands, allowing connection of appropriate types of cable or conduit, and the appliance allows the connection of the supply conductors after the appliance has been fixed to its support		<b>P</b>
527.		For a fixed appliance constructed so that parts can be removed to facilitate easy installation, this requirement is met if it is possible to connect the fixed wiring without difficulty after a part of the appliance has been fixed to its support		<b>P</b>
528.	25.4	Cable and conduit entries, rated current of appliance not exceeding 16 A, dimensions according to table 10		<b>P</b>
529.		Introduction of conduit or cable does not reduce clearances or creepage distances below values specified in 29		<b>P</b>
	25.5	Method for assembling the supply cord to the appliance:		
530.		- type X attachment		<b>NA</b>
531.		- type Y attachment		<b>P</b>
532.		- type Z attachment, if allowed in part 2		<b>NA</b>
533.		Type X attachment, other than those with a specially prepared cord, not used for flat twin tinsel cords		<b>NA</b>



**LAB RECORDS**  
**FORM 201-4117-TRF-E**

page: 40/85

(Lab Record S/N):

**504231-E**

Seq. No	Paragraphs	Requirements	Results Measurements Remarks	Verdict
534.		For multi-phase appliances supplied with a supply cord and that are intended to be permanently connected to fixed wiring, the supply cord is assembled to the appliance by type Y attachment.		NA
535.	25.6	Plugs fitted with only one flexible cord		NA
	25.7	Supply cords being one of the following types:		
536.		rubber sheathed (at least 60245 IEC 53)		NA
537.		polychloroprene sheathed (at least 60245 IEC 57)		NA
538.		cross-linked polyvinyl chloride sheathed (at least 60245 IEC 87)		NA
		Polyvinyl chloride sheathed: Not used if they are likely to touch metal parts having a temperature rise exceeding 75K during the test of Clause 11.		
539.		- light polyvinyl chloride sheathed cord (at least 60227 IEC 52), appliances not exceeding 3 kg		NA
540.		- ordinary polyvinyl chloride sheathed cord (at least 60227 IEC 53), other appliances		NA
		Heat resistant polyvinyl chloride sheathed: Not used for type X attachment other than specially prepared cords.		
541.		- Heat-resistant light polyvinyl chloride sheathed cord (at least 60227 IEC 56), appliances not exceeding 3 kg		NA
542.		- heat-resistant polyvinyl chloride sheathed cord (60227 IEC 57), other appliances		NA
543.		Supply cords for class III appliances adequately insulated.		NA
544.		Test with 500 V for 2 min for supply cords of class III appliances that contain live parts.		NA
545.	25.8	Nominal cross-sectional area of supply cords according to table 11; rated current (A); cross-sectional area (mm <sup>2</sup> ).....:		NA
546.	25.9	Supply cord not in contact with sharp points or edges		NA
547.	25.10	Green/yellow core for earthing purposes in Class I appliance		NA
548.	25.11	Conductors of supply cords not consolidated by lead-tin soldering		NA



**LAB RECORDS**  
**FORM 201-4117-TRF-E**

page: 41/85

**(Lab Record S/N): 504231-E**

Seq. No	Paragraphs	Requirements	Results Measurements Remarks	Verdict
		where they are subject to contact pressure, unless		
549.		the contact pressure is provided by spring terminals.		NA
550.	25.12	Insulation of the supply cord not damaged when moulding the cord to part of the enclosure		NA
551.	25.13	Inlet opening so shaped as to prevent damage to the supply cord		P
552.		If the enclosure at the inlet opening is of insulation material, a non-detachable lining or bushing complying with 29.3 for supplementary insulation provided.	the enclosure at the inlet opening is of insulating material (cable gland)	NA
553.		If unsheathed supply cord, a similar additional bushing or lining is required, unless the appliance is		NA
554.		class 0 or		NA
555.		a class III appliance not containing live parts.		NA
556.	25.14	Supply cords moved while in operation adequately protected against excessive flexing.		NA
		Flexing test as described::		
557.		- applied force (N) .....		NA
558.		- number of flexings.....		NA
559.		The tests does not result in:		NA
560.		- short circuit between the conductors such that the current exceeds a value of twice the rated current		NA
561.		- breakage of more than 10% of the strands of any conductor		NA
562.		- separation of the conductor from its terminal		NA
563.		- loosening of any cord guard		NA
564.		- damage to the cord or the cord guard		NA
565.		- broken strands piercing the insulation and becoming accessible		NA
566.	25.15	For appliances with supply cord and appliances to be permanently connected to fixed wiring by a flexible cord, conductors of the supply cord relieved from strain, twisting and		P



**LAB RECORDS**  
**FORM 201-4117-TRF-E**

page: 42/85

(Lab Record S/N):

**504231-E**

Seq. No	Paragraphs	Requirements	Results Measurements Remarks	Verdict
		abrasion by use of cord anchorage.		
567.		The cord cannot be pushed into the appliance to such an extent that the cord or internal parts of the appliance can be damaged		<b>P</b>
568.		Pull and torque test of supply cord, values shown in table 10: mass (kg); pull (N); torque (not on automatic cord reel); (Nm).....	> 4kg; 100N; 0,35Nm	<b>P</b>
569.		Max. 2 mm displacement of the cord, and conductors not moved more than 1 mm in the terminals	Max. 0,1mm	<b>P</b>
	25.16	Cord anchorages for type X attachments constructed and located so that:		
570.		- replacement of the cord is easily possible		<b>NA</b>
571.		- it is clear how the relief from strain and the prevention of twisting are obtained		<b>NA</b>
572.		- they are suitable for different types of cord		<b>NA</b>
573.		- cord cannot touch the clamping screws of cord anchorage if these screws are accessible, unless		<b>NA</b>
574.		they are separated from accessible metal parts by supplementary insulation		<b>NA</b>
575.		- the cord is not clamped by a metal screw which bears directly on the cord		<b>NA</b>
576.		- at least one part of the cord anchorage securely fixed to the appliance, unless		<b>NA</b>
577.		it is part of a specially prepared cord		<b>NA</b>
578.		- screws which have to be operated when replacing the cord do not fix any other component, unless		<b>NA</b>
579.		the appliance becomes inoperative or incomplete or the parts cannot be removed without a tool.		<b>NA</b>
580.		- if labyrinths can be bypassed the test of 25.15 is nevertheless withstood		<b>NA</b>
581.		- for Class 0, 0I and I appliances: they are of insulating material or are provided with an insulating lining, unless		<b>NA</b>



**LAB RECORDS**  
**FORM 201-4117-TRF-E**

page: 43/85

(Lab Record S/N):

**504231-E**

Seq. No	Paragraphs	Requirements	Results Measurements Remarks	Verdict
582.		failure of the insulation of the cord does not make accessible metal parts live		NA
583.		- for Class II appliances: they are of insulating material, or		NA
584.		if of metal, they are insulated from accessible metal parts by supplementary insulation		NA
585.	25.17	Adequate cord anchorages for type Y and Z attachment, test with the cord supplied with the appliance.		NA
586.	25.18	Cord anchorages only accessible with the aid of a tool, or		NA
587.		so constructed that the cord can only be fitted with the aid of a tool		NA
588.	25.19	Type X attachment, glands not used as cord anchorage in portable appliances		NA
589.		Tying the cord into a knot or tying the cord with string not used		NA
590.	25.20	The insulated conductors of the supply cord for type Y and Z attachment additionally insulated from accessible metal parts.		NA
	25.21	Space for supply cord for type X attachment or for connection of fixed wiring constructed:		
591.		- to permit checking of conductors with respect to correct positioning and connection before fitting the cover		NA
592.		- so there is no risk of damage to the conductors or their insulation when fitting the cover.		NA
593.		- for portable appliances, so that the uninsulated end of a conductor if it becomes free from the terminal, prevented from contact with accessible metal parts		NA
	25.22	Appliance inlets:		
594.		- live parts not accessible during insertion or removal		NA
595.		Requirement not applicable to appliance inlets complying with IEC 60320-1		NA
596.		- connector can be inserted without difficulty		NA



**LAB RECORDS**  
**FORM 201-4117-TRF-E**

page: 44/85

(Lab Record S/N):

**504231-E**

Seq. No	Paragraphs	Requirements	Results Measurements Remarks	Verdict
597.		- the appliance is not supported by the connector		NA
598.		- is not for cold conditions if temp. rise of external metal parts exceeds 75 K, unless		NA
599.		the supply cord is not likely to touch such metal parts		NA
600.	25.23	Interconnection cords comply with the requirements for the supply cord, except that:		NA
601.		- the cross-sectional area of the conductors is determined on the basis of the maximum current during clause 11		NA
602.		- the thickness of the insulation may be reduced		NA
603.		If necessary, electric strength test of 16.3		NA
604.	25.24	Interconnection cords not detachable without the aid of a tool if compliance with the standard is impaired when they are disconnected		NA
605.	25.25	Dimensions of pins compatible with the dimensions of the relevant socket-outlet.		NA
606.		Dimensions of pins and engagement face in accordance with the relevant plug in IEC 60083		NA
	<b>26</b>	<b>TERMINALS FOR EXTERNAL CONDUCTORS</b>		
607.	26.1	Appliances provided with terminals or equally effective devices for connection of external conductors		NA
608.		Terminals only accessible after removal of a non-detachable cover, except		P
609.		for class III appliances that do not contain live parts.		NA
610.		Earthing terminals may be accessible if a tool is required to make the connections and means are provided to clamp the wire independently from its connection.		NA
611.	26.2	Appliances with type X attachment and appliances for connection to fixed wiring provided with terminals in which connections are made by means of screws, nuts or similar devices, unless		P



**LAB RECORDS**  
**FORM 201-4117-TRF-E**

page: 45/85

(Lab Record S/N):

**504231-E**

Seq. No	Paragraphs	Requirements	Results Measurements Remarks	Verdict
612.		the connections are soldered		NA
613.		Screws and nuts serve only to clamp supply conductors, except		P
614.		internal conductors, if so arranged that they are unlikely to be displaced when fitting the supply conductors		NA
615.		If soldered connections used, the conductor so positioned or fixed that reliance is not placed on soldering alone, unless		NA
616.		barriers provided, so that neither clearances nor creepage distances between live parts and other metal parts reduced below the values for supplementary insulation if the conductor becomes free at the soldered joint.		NA
617.	26.3	Terminals for type X attachment and for connection of cables to fixed wiring so constructed that the conductor is clamped between metal surfaces with sufficient contact pressure but without damaging the conductor		NA
		Terminals for type X attachment and those for connection to fixed wiring so fixed that when tightening or loosening the clamping means:		
618.		- the terminal does not loosen		P
619.		- internal wiring is not subjected to stress		P
620.		- clearances and creepage distances are not reduced below the values in 29		P
621.		Compliance checked by inspection and by the test of subclause 9.6 of IEC 60999-1, the torque applied being equal to two-thirds of the torque specified. Nominal diameter of thread (mm); screw category; torque (Nm) .....	3,86/II/0,8	P
622.		No deep or sharp indentations of the conductors.		P
623.	26.4	Terminals for type X attachment, except those having a specially prepared cord and those for the connection of cables of fixed wiring, no special preparation of conductors such as by soldering, use of cable lugs, eyelets or similar, and		NA



**LAB RECORDS**  
**FORM 201-4117-TRF-E**

page: 46/85

(Lab Record S/N):

**504231-E**

Seq. No	Paragraphs	Requirements	Results Measurements Remarks	Verdict
624.		so constructed or placed that conductors prevented from slipping out when clamping screws or nuts are tightened		NA
625.	26.5	Terminals for type X attachment so located or shielded that if a wire of a stranded conductor escapes, no risk of accidental connection to other parts that result in a hazard		NA
626.		Stranded conductor test, 8 mm insulation removed		NA
627.		No contact between live parts and accessible metal parts and,		NA
628.		for class II constructions, between live parts and metal parts separated from accessible metal parts by supplementary insulation only		NA
629.	26.6	Terminals for type X attachment and for connection to fixed wiring suitable for connection of conductors with required cross-sectional area according to table 13; rated current (A); nominal cross-sectional area (mm <sup>2</sup> ) .....		NA
630.		If a specially prepared cord is used, terminals need only be suitable for that cord		NA
631.	26.7	Terminals for type X attachment, except in class III appliances not containing live parts, accessible after removal of a cover or part of the enclosure		NA
632.	26.8	Terminals for the connection to fixed wiring, including the earthing terminal, located close to each other		P
633.	26.9	Terminals of the pillar type constructed and located as specified		P
634.	26.10	Terminals with screw clamping and screwless terminals not used for flat twin tinsel cords, unless		P
635.		conductors ends fitted with a device suitable for screw terminals		NA
636.		Pull test of 5 N to the connection		NA
637.	26.11	For type Y and Z attachment: soldered, welded, crimped and similar connections may be used	Type Y	P



**LAB RECORDS**  
**FORM 201-4117-TRF-E**

page: 47/85

(Lab Record S/N):

**504231-E**

Seq. No	Paragraphs	Requirements	Results Measurements Remarks	Verdict
638.		For Class II appliances: the conductor so positioned or fixed that reliance is not placed on soldering, welding or crimping alone		NA
639.		If soldering, welding or crimping alone used, barriers provided so that clearances and creepage distances between live parts and other metal parts are not reduced below the values for supplementary insulation if the conductor becomes free		NA
	27	<b>PROVISION FOR EARTHING</b>		
640.	27.1	Accessible metal parts of Class 0I and I appliances, permanently and reliably connected to an earthing terminal or contact of the appliance inlet		P
641.		Earthing terminals and earthing contacts not connected to neutral terminal		P
642.		Class 0, II and III appliance have no provision for earthing		NA
643.		Safety extra-low voltage circuits not earthed, unless		NA
644.		protective extra-low voltage circuits		NA
645.	27.1 (EN 60335-2-21)	For class I water heaters, the sheath of the heating element shall be permanently and reliably connected to the earthing terminal unless		P
646.	27.1 (EN 60335-2-21)	– the container is provided with inlet and outlet pipes of metal that are permanently and reliably connected to the earthing terminal, and		NA
647.	27.1 (EN 60335-2-21)	– other accessible metal parts of the container in contact with the water are permanently and reliably connected to the earthing terminal		NA
648.	27.2	Clamping means adequately secured against accidental loosening		P
649.		Terminals used for the connection of external equipotential bonding conductors allow connection of conductors of 2.5 to 6 mm <sup>2</sup> , and		NA
650.		do not provide earthing continuity between different parts of the appliance, and		NA
651.		conductors cannot be loosened without the aid of a tool		NA



**LAB RECORDS**  
**FORM 201-4117-TRF-E**

page: 48/85

(Lab Record S/N):

**504231-E**

Seq. No	Paragraphs	Requirements	Results Measurements Remarks	Verdict
652.	27.3	For detachable parts that are plugged into another part of the appliance, and having an earth connection, the earth connection made before and separated after current-carrying connections when removing the part		NA
653.		For appliances with supply cord, current-carrying conductors become taut before earthing conductor, if the cord slips out of the cord anchorage		NA
654.	27.4	No risk of corrosion resulting from contact between metal of earthing terminal and other metal		P
655.		Adequate resistance to corrosion of coated or uncoated parts providing earthing continuity, other than parts of a metal frame or enclosure		P
656.		Parts of steel providing earthing continuity provided at the essential areas with an electroplated coating, thickness at least 5µm		NA
657.		Adequate protection against rusting of parts of coated or uncoated steel, only intended to provide or transmit contact pressure		NA
658.		In case of aluminium alloys precautions taken to avoid risk of corrosion		NA
659.	27.5	Low resistance of connection between earthing terminal and earthed metal parts		P
660.		This requirement does not apply to connections providing earthing continuity in the protective extra-low voltage circuit, provided that clearances of basic insulation are based on the rated voltage of the appliance		NA
661.		Resistance not exceeding 0,1 Ω at the specified low-resistance test (Ω).....:	0,012 Ω	P
662.	27.6	The printed conductors of printed circuit boards shall not be used to provide earthing continuity in handheld appliances.		NA
663.		They may be used to provide earthing continuity in other appliances if at least two tracks are used with independent soldering points and the appliance complies with 27.5 for each circuit		NA



**LAB RECORDS**  
**FORM 201-4117-TRF-E**

page: 49/85

(Lab Record S/N):

**504231-E**

Seq. No	Paragraphs	Requirements	Results Measurements Remarks	Verdict
	28	<b>SCREWS AND CONNECTIONS</b>		
664.	28.1	Fixings, electrical connections and connections providing earthing continuity withstand mechanical stresses		P
665.		Screws not of soft metal liable to creep, such as zinc or aluminium		P
666.		Diameter of screws of insulating material min. 3 mm		NA
667.		Screws of insulating material not used for any electrical connection or connections providing earthing continuity		P
668.		Screws used for electrical connections or connections providing earthing continuity screw into metal		P
669.		Screws not of insulating material if their replacement by a metal screw can impair supplementary or reinforced insulation		NA
670.		Type X attachment, screws to be removed for replacement of supply cord or for user maintenance, not of insulating material if their replacement by a metal screw can impair basic insulation		NA
671.		For screws and nuts; test as specified in table 14.....:	(see appended table 28.1)	P
672.	28.2	Electrical connections and connections providing earthing continuity constructed so that contact pressure not transmitted through insulating material liable to shrink or distort, unless		P
673.		there is resiliency in the metallic parts to compensate for shrinkage or distortion of the insulating material		NA
		This requirement does not apply to electrical connections in circuits of appliances for which: carrying a current not exceeding 0.5A		
674.		30.2.2 is applicable and that carry a current not exceeding 0,5 A		NA
675.		30.2.3 is applicable and that carry a current not exceeding 0,2 A		NA
676.	28.3	Space-threaded (sheet metal) screws only used for electrical connections if they clamp the parts together		NA



**LAB RECORDS**  
**FORM 201-4117-TRF-E**

page: 50/85

(Lab Record S/N):

**504231-E**

Seq. No	Paragraphs	Requirements	Results Measurements Remarks	Verdict
677.		Thread-cutting (self-tapping) screws and thread rolling screws only used for electrical connections if they generate a full form standard machine screw thread		<b>NA</b>
678.		Thread-cutting (self-tapping) screws not used if they are likely to be operated by the user or installer		<b>NA</b>
		Thread-cutting, thread rolling and space threaded screws may be used in connections providing earthing continuity provided it is not necessary to disturb the connection:		
679.		- in normal use,		<b>NA</b>
680.		- during user maintenance,		<b>NA</b>
681.		- when replacing a supply cord having a type X attachment, or		<b>NA</b>
682.		- during installation		<b>NA</b>
683.		At least two screws being used for each connection providing earthing continuity, unless		<b>NA</b>
684.		the screw forms a thread having a length of at least half the diameter of the screw		<b>P</b>
685.	28.4	Screws and nuts that make mechanical connection secured against loosening if they also make electrical connections or connections providing earthing continuity		<b>NA</b>
686.		This requirement does not apply to screws in the earthing circuit if at least two screws are used, or		<b>NA</b>
687.		if an alternative earthing circuit is provided.		<b>NA</b>
688.		Rivets for electrical connections or connections providing earthing continuity secured against loosening if subjected to torsion		<b>NA</b>
	29	<b>CLEARANCES, CREEPAGE DISTANCES AND SOLID INSULATION</b>		
689.		Clearances, creepage distances and solid insulation withstand electrical stress		<b>P</b>
690.		For coatings used on printed circuits boards to protect the microenvironment (Type 1) or to provide basic insulation (Type 2), annex J applies .....		<b>NA</b>



**LAB RECORDS**  
**FORM 201-4117-TRF-E**

page: 51/85

(Lab Record S/N):

**504231-E**

Seq. No	Paragraphs	Requirements	Results Measurements Remarks	Verdict
691.		The microenvironment is pollution degree 1 under Type 1 coating		NA
692.		For type 2 protection, the spacing between the conductors before the protection is applied is not less than the values specified in Table 1 of IEC 60664-3		NA
693.		These values apply to functional, basic, supplementary and reinforced insulation.....:		NA
694.	29.1	Clearances not less than the values specified in table 16, taking into account the rated impulse voltage for the overvoltage categories of table 15, unless.....:	(see appended table)	NA
695.		for basic insulation and functional insulation they comply with the impulse voltage test of clause 14		NA
696.		However, if the construction is affected by wear, distortion, movement of the parts or during assembly, the clearances for rated impulse voltages of 1500V and above are increased by 0,5 mm and the impulse voltage test is not applicable		NA
		Impulse voltage test not applicable:		
697.		- when the microenvironment is pollution degree 3, or		P
698.		- for basic insulation of class 0 and class 01 appliances		P
699.		Appliances are in overvoltage category II		P
700.		A force of 2 N is applied to bare conductors, other than heating elements		NA
701.		A force of 30 N is applied to accessible surfaces		P
702.	29.1.1	Clearances of basic insulation withstand the overvoltages, taking into account the rated impulse voltage		P
703.		The values of table 16 or the impulse voltage test of clause 14 are applicable.....:	(see appended table)	NA
704.		Clearance at the terminals of tubular sheathed heating elements may be reduced to 1 mm if the microenvironment is pollution degree 1		NA



**LAB RECORDS**  
**FORM 201-4117-TRF-E**

(Lab Record S/N):

**504231-E**

Seq. No	Paragraphs	Requirements	Results Measurements Remarks	Verdict
705.		Lacquered conductors of windings considered to be bare conductors		NA
706.	29.1.2	Clearances of supplementary insulation not less than those specified for basic insulation in table 16.....:	(see appended table)	NA
707.	29.1.3	Clearances of reinforced insulation not less than those specified for basic insulation in table 16, but using the next higher step for rated impulse voltage.....:	(see appended table)	P
708.		For double insulation, with no intermediate conductive part between basic and supplementary insulation, clearances are measured between live parts and the accessible surface, and the insulation system is treated as reinforced insulation.		NA
	29.1.4	Clearances for functional insulation are the largest values determined from:		
709.		- table 16 based on the rated impulse voltage .....	(see appended table)	NA
710.		- table F.7a in IEC 60664-1, frequency not exceeding 30 kHz		NA
711.		- clause 4 of IEC 60664-4, frequency exceeding 30 kHz		NA
712.		If values of table 16 are largest, the impulse voltage test of clause 14 may be applied instead, unless		NA
713.		the microenvironment is pollution degree 3, or		NA
714.		the distances can be affected by wear, distortion, movement of the parts or during assembly		NA
715.		However, clearances are not specified if the appliance complies with clause 19 with the functional insulation short-circuited		NA
716.		Lacquered conductors of windings considered to be bare conductors		NA
717.		However, clearances at crossover points are not measured		NA
718.		Clearance between surfaces of PTC heating elements may be reduced to 1 mm		NA
	29.1.5	Appliances having higher working voltages than rated voltage, clearances for basic insulation are the largest values determined from:		



**LAB RECORDS**  
**FORM 201-4117-TRF-E**

page: 53/85

(Lab Record S/N):

**504231-E**

Seq. No	Paragraphs	Requirements	Results Measurements Remarks	Verdict
719.		- table 16 based on the rated impulse voltage .....		NA
720.		- table F.7a in IEC 60664-1, frequency not exceeding 30 kHz		NA
721.		- clause 4 of IEC 60664-4, frequency exceeding 30 kHz		NA
722.		If clearances for basic insulation are selected from Table F.7a of IEC 60664-1 or Clause 4 of IEC 60664-4, the clearances of supplementary insulation are not less than those specified for basic insulation		NA
723.		If clearances for basic insulation are selected from Table F.7a of IEC 60664-1, the clearances of reinforced insulation dimensioned as specified in Table F.7a are to withstand 160% of the withstand voltage required for basic insulation.		NA
724.		If clearances for basic insulation are selected from Clause 4 of IEC 60664-4, the clearances of reinforced insulation are twice the value required for basic insulation		NA
725.		If the secondary winding of a step-down transformer is earthed, or if there is an earthed screen between the primary and secondary windings, clearances of basic insulation on the secondary side not less than those specified in table 16, but using the next lower step for rated impulse voltage		NA
726.		Circuits supplied with a voltage lower than rated voltage, clearances of functional insulation based on the working voltage used as the rated voltage in table 15		NA
727.	29.2	Creepage distances not less than those appropriate for the working voltage, taking into account the material group and the pollution degree.....	(see appended table)	P
728.		Pollution degree 2 applies, unless		NA
729.		- precautions taken to protect the insulation; pollution degree 1		NA
730.		- insulation subjected to conductive pollution; pollution degree 3		P



**LAB RECORDS**  
**FORM 201-4117-TRF-E**

page: 54/85

(Lab Record S/N):

**504231-E**

Seq. No	Paragraphs	Requirements	Results Measurements Remarks	Verdict
731.		A force of 2 N is applied to bare conductors, other than heating elements.		NA
732.		A force of 30 N is applied to accessible surfaces.		P
733.		In a double insulation system, the working voltage for both the basic and supplementary insulation is taken as the working voltage across the complete double insulation system.		NA
734.	29.2.1	Creepage distances of basic insulation not less than specified in table 17.....:	(see appended table)	P
735.		However, if the working voltage is periodic and has a frequency exceeding 30 kHz, the creepage distances are also determined from table 2 of IEC 60664-4, these values being used if exceeding the values in table 17.....:		NA
736.		Except for pollution degree 1, creepage distance not less than the minimum specified for the clearance in table 16, if the clearance has been checked according to the test of clause 14.....:		NA
737.	29.2.2	Creepage distances of supplementary insulation at least as specified for basic insulation in table 17, or		NA
738.		Table 2 of IEC 60664-4, as applicable.:		NA
739.	29.2.3	Creepage distances of reinforced insulation at least double as specified for basic insulation in table 17, or	(see appended table)	P
740.		Table 2 of IEC 60664-4, as applicable.:		NA
741.	29.2.4	Creepage distances of functional insulation not less than specified in table 18.....:		NA
742.		However, if the working voltage is periodic and has a frequency exceeding 30 kHz, the creepage distances are also determined from table 2 of IEC 60664-4, these values being used if exceeding the values in table 18.....:		NA



**LAB RECORDS**  
**FORM 201-4117-TRF-E**

page: 55/85

(Lab Record S/N):

**504231-E**

Seq. No	Paragraphs	Requirements	Results Measurements Remarks	Verdict
743.		Creepage distances may be reduced if the appliance complies with clause 19 with the functional insulation short-circuited		NA
744.	29.3	Supplementary and reinforced insulation having adequate thickness, or a sufficient number of layers, to withstand the electrical stresses		P
745.		Compliance checked by:		
746.		- measurement, in accordance with 29.3.1, or		P
747.		- an electric strength test in accordance with 29.3.2, or		P
748.		- an assessment of the thermal quality of the material combined with an electric strength test, in accordance with 29.3.3		NA
749.		for accessible parts of reinforced insulation consisting of a single layer, by measurement in accordance with 29.3.4, or		NA
750.		- as specified in subclause 6.3 of IEC 60664-4 for insulation that is subjected to any periodic voltage having a frequency exceeding 30 kHz		NA
751.	29.3.1	Supplementary insulation having a thickness of at least 1 mm		NA
752.		Reinforced insulation having a thickness of at least 2 mm		P
753.	29.3.2	Each layer of material withstand the electric strength test of 16.3 for supplementary insulation		NA
754.		Supplementary insulation consisting of at least 2 layers		NA
755.		Reinforced insulation consisting of at least 3 layers		NA
756.	29.3.3	The insulation is subjected to the dry heat test Bb of IEC 60068-2-2, followed by		NA
757.		the electric strength test of 16.3		NA
758.		If the temperature rise during the tests of Clause 19 does not exceed the value specified in Table 3, the test of IEC 60068-2-2 is not carried out		P



**LAB RECORDS**  
**FORM 201-4117-TRF-E**

page: 56/85

(Lab Record S/N):

**504231-E**

Seq. No	Paragraphs	Requirements	Results Measurements Remarks	Verdict
759.	29.3.4	Thickness of accessible parts of reinforced insulation consisting of a single layer not less than specified in table 19.....:		<b>NA</b>
760.	30	<b>RESISTANCE TO HEAT AND FIRE</b>		
761.	30.1	External parts of non-metallic material,		<b>P</b>
762.		parts supporting live parts, and		<b>P</b>
763.		parts of thermoplastic material providing supplementary or reinforced insulation,		<b>P</b>
764.		sufficiently resistant to heat		<b>P</b>
765.		Ball-pressure test according to IEC 60695-10-2		<b>P</b>
766.		External parts: at 40°C plus the maximum temperature rise determined during the test of clause 11, or at 75°C, whichever is the higher; temperature(°C).....:	(see appended table) 75°C	<b>P</b>
767.		Parts supporting live parts at 40°C plus the maximum temperature rise determined during the test of clause 11, or at 125°C, whichever is the higher; temperature (°C).....:	125°C	<b>P</b>
768.		Parts of thermoplastic material providing supplementary or reinforced insulation, 25°C plus the maximum temperature rise determined during clause 19, if higher; temperature (°C):.		<b>NA</b>
769.	30.2	Parts of non-metallic material adequately resistant to ignition and spread of fire		<b>P</b>
770.		This requirement does not apply to		<b>NA</b>
771.		parts having a mass not exceeding 0,5 g, provided the cumulative effect is unlikely to propagate flames that originate inside the appliance by propagating flames from one part to another, or		<b>NA</b>
772.		decorative trims, knobs and other parts unlikely to be ignited or to propagate flames that originate inside the appliance		<b>NA</b>
773.		Compliance checked by the test of 30.2.1. and in addition:		<b>P</b>
774.		- attended appliances, 30.2.2 applies		<b>NA</b>



**LAB RECORDS**  
**FORM 201-4117-TRF-E**

page: 57/85

(Lab Record S/N):

**504231-E**

Seq. No	Paragraphs	Requirements	Results Measurements Remarks	Verdict
775.		- unattended appliances, 30.2.3 applies		P
776.		Appliances for remote operation, 30.2.3 applies		NA
777.		Base material of printed circuit board, 30.2.4 applies		NA
778.	30.2.1	Glow-wire test of IEC 60695-2-11 at 550 °C		P
779.		However, test not carried out if the material is classified as having a glow-wire flammability index according to IEC 60695-2-12 of at least 550°C, or		NA
780.		the material is classified at least HB40 according to IEC 60695-11-10		NA
781.		Parts for which the glow-wire test cannot be carried out meet the requirements in ISO 9772 for category HBF material		NA
782.	30.2.2	Appliances operated while attended, parts of non-metallic material supporting current-carrying connections, and		NA
783.		parts of non-metallic material within a distance of 3mm of such connections,		NA
784.		are subjected to the glow-wire test of IEC 60695-2-11.		NA
		The test severity is:		
785.		- 750°C, for connections carrying a current exceeding 0,5A during normal operation		NA
786.		- 650°C, for other connections		NA
787.		Glow-wire applied to an interposed shielding material, if relevant.		NA
		The glow-wire test is not carried out on parts of material classified as having a glow-wire flammability index according to IEC 60695-2-12 of at least:		
788.		- 750°C, for connections carrying a current exceeding 0,5A during normal operation		NA
789.		- 650°C, for other connections		NA
		The glow-wire test is also not carried out on small parts. These parts are to:		
790.		- comprise material having a glow-wire flammability index of at least 750 °C, or 650 °C as appropriate, or		NA



**LAB RECORDS**  
**FORM 201-4117-TRF-E**

page: 58/85

(Lab Record S/N):

**504231-E**

Seq. No	Paragraphs	Requirements	Results Measurements Remarks	Verdict
791.		- comply with the needle-flame test of Annex E, or		NA
792.		- comprise material classified as V-0 or V-1 according to IEC 60695-11-10..:		NA
793.		Test not applicable to conditions as specified.....:		NA
794.	30.2.3	Appliances that are operated while unattended are tested as specified in 30.2.3.1 and 30.2.3.2.		P
795.		The tests are not applicable to conditions as specified .....		NA
796.	30.2.3.1	Parts of non-metallic material supporting connections that carry a current exceeding 0,2 A during normal operation, and		P
797.		parts of non-metallic material, other than small parts, within a distance of 3 mm		NA
798.		subjected to the glow-wire test of IEC 60695-2-11 with a test severity of 850°C		P
799.		Glow-wire applied to an interposed shielding material, if relevant.		NA
800.		The glow-wire test is not carried out on parts of material classified as having a glow-wire flammability index according to IEC 60695-2-12 of at least 850°C		NA
801.	30.2.3.2	Parts of non-metallic material supporting current-carrying connections, and		NA
802.		parts of non-metallic material within a distance of 3 mm of such connections,		NA
803.		are subjected to the glow-wire test of IEC 60695-2-11		NA
		The test severity is:		
804.		- 750°C, for connections carrying a current exceeding 0,5A during normal operation		NA
805.		- 650°C, for other connections		NA
806.		Glow-wire applied to an interposed shielding material, if relevant.		NA
		However, the glow-wire test of 750 °C or 650 °C as appropriate, is not carried out on parts of material fulfilling both or either of the following classifications:		
807.		- a glow-wire ignition temperature according to IEC 60695-2-13 of at		NA



**LAB RECORDS**  
**FORM 201-4117-TRF-E**

page: 59/85

(Lab Record S/N):

**504231-E**

Seq. No	Paragraphs	Requirements	Results Measurements Remarks	Verdict
		least:		
808.		- 775 °C, for connections that carry a current exceeding 0,2 A during normal operation,		<b>NA</b>
809.		- 675 °C, for other connections		<b>NA</b>
810.		- a glow-wire flammability index according to IEC 60695-2-12 of at least:		<b>NA</b>
811.		- 750°C, for connections carrying a current exceeding 0,2A during normal operation		<b>NA</b>
812.		- 650°C, for other connections		<b>NA</b>
		The glow-wire test is also not carried out on small parts. These parts are to:		
813.		- comprise material having a glow-wire ignition temperature of at least 775 °C or 675 °C as appropriate, or		<b>NA</b>
814.		- comprise material having a glow-wire flammability index of at least 750 °C or 650 °C as appropriate, or		<b>NA</b>
815.		- comply with the needle-flame test of Annex E, or		<b>NA</b>
816.		- comprise material classified as V-0 or V-1 according to IEC 60695-11-10..:		<b>NA</b>
		The consequential needle-flame test of Annex E applied to non-metallic parts that encroach within the vertical cylinder placed above the centre of the connection zone and on top of the non-metallic parts supporting current-carrying connections, and parts of non-metallic material within a distance of 3 mm of such connections if these parts are those:		
817.		- parts that withstood the glow-wire test of IEC 60695-2-11 of 750 °C or 650 °C as appropriate, but produce a flame that persist longer than 2 s, or		<b>NA</b>
818.		- parts that comprised material having a glow-wire flammability index of at least 750 °C or 650 °C as appropriate, or		<b>NA</b>
819.		- small parts, that comprised material having a glow-wire flammability index of at least 750°C or 650°C as appropriate, or		<b>NA</b>
820.		- small parts for which the needle-flame test of Annex E was applied, or		<b>NA</b>



**LAB RECORDS**  
**FORM 201-4117-TRF-E**

page: 60/85

**(Lab Record S/N): 504231-E**

Seq. No	Paragraphs	Requirements	Results Measurements Remarks	Verdict
821.		- small parts for which a material classification of V-0 or V-1 was applied		NA
		However, the consequential needle-flame test is not carried out on non-metallic parts, including small parts, within the cylinder that are:		
822.		- parts having a glow-wire ignition temperature of at least 775 °C or 675 °C as appropriate, or		NA
823.		- parts comprising material classified as V-0 or V-1 according to IEC 60695-11-10, or		NA
824.		- parts shielded by a flame barrier that meets the needle-flame test of Annex E or that comprises material classified as V-0 or V-1 according to IEC 60695-11-10		NA
825.	30.2.4	Base material of printed circuit boards subjected to needle-flame test of annex E		NA
826.		Test not applicable to conditions as specified.....:		NA
	31	<b>RESISTANCE TO RUSTING</b>		
827.		Relevant ferrous parts adequately protected against rusting.		P
	32	<b>RADIATION, TOXICITY AND SIMILAR HAZARDS</b>		
828.		Appliance shall not emit harmful radiation, present a toxic or similar hazard due to their operation in normal use		P
829.		Relevant tests specified in part 2, if necessary		NA
	<b>A</b>	<b>ANNEX A (INFORMATIVE) ROUTINE TESTS</b>		
830.		Description of routine tests to be carried out by the manufacturer		
	<b>B</b>	<b>ANNEX B (NORMATIVE) APPLIANCES POWERED BY RECHARGEABLE BATTERIES</b>		
831.		The following modifications to this standard are applicable for appliances powered by batteries that are recharged in the appliance		NA
832.		This annex does not apply to battery chargers		NA
	3.1.9	Appliance operated under the following conditions:		
833.		the appliance, supplied by its fully		NA

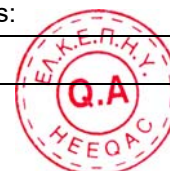

**LAB RECORDS**  
**FORM 201-4117-TRF-E**

page: 61/85

(Lab Record S/N):

**504231-E**

Seq. No	Paragraphs	Requirements	Results Measurements Remarks	Verdict
		charged battery, operated as specified in relevant part 2		
834.		-the battery is charged, the battery being initially discharged to such an extent that the appliance cannot operate		<b>NA</b>
835.		-if possible, the appliance is supplied from the supply mains through its battery charger, the battery being initially discharged to such an extent that the appliance cannot operate. The appliance is operated as specified in relevant part 2		<b>NA</b>
836.		If the appliance incorporates inductive coupling between two parts that are detachable from each other, the appliance is supplied from the supply mains with the detachable part removed		<b>NA</b>
837.	3.6.2	Part to be removed in order to discard the battery is not considered to be detachable		<b>NA</b>
838.	5.101	Appliances supplied from the supply mains tested as specified for motor-operated appliances		<b>NA</b>
839.	7.1	Battery compartment for batteries intended to be replaced by the user, marked with battery voltage and polarity of the terminals		<b>NA</b>
840.	7.12	The instructions for appliances incorporating batteries intended to be replaced by the user includes required information		<b>NA</b>
841.		Details about how to remove batteries containing materials hazardous to the environment given		<b>NA</b>
842.	7.15	Markings placed on the part of the appliance connected to the supply mains		<b>NA</b>
843.	8.2	Appliances having batteries that according to the instruction may be replaced by the user need only have basic insulation between live parts and the inner surface of the battery compartment		<b>NA</b>
844.		If the appliance can be operated without batteries, double or reinforced insulation required		<b>NA</b>
845.	11.7	The battery is charged for the period		<b>NA</b>



**LAB RECORDS**  
**FORM 201-4117-TRF-E**

page: 62/85

(Lab Record S/N):

**504231-E**

Seq. No	Paragraphs	Requirements	Results Measurements Remarks	Verdict
		described		
846.	19.1	Appliances subjected to tests of 19.101, 19.102 and 19.103		NA
847.	19.101	Appliances supplied at rated voltage for 168 h, the battery being continually charged		NA
848.	19.102	Short-circuiting of the terminals of the battery, being fully charged, for appliances having batteries that can be removed without the aid of a tool		NA
849.	19.103	Appliances having batteries replaceable by the user supplied at rated voltage under normal operation with the battery removed or in any position allowed by the construction		NA
850.	21.101	Appliances having pins for insertion into socket-outlets have adequate mechanical strength, checked according to procedure 2 of IEC 68-2-32		NA
		Part of the appliance incorporating the pins subjected to the free fall test, procedure 2, of IEC 60068-2-32, the number of falls being:		
851.		100, the mass of part does not exceed 250g		NA
852.		the mass of part exceeds 250 g		NA
853.		After the test, the requirements of 8.1, 15.1.1, 16.3 and clause 29 are met		NA
854.	22.3	Appliances having pins for insertion into socket-outlets tested as fully assembled as possible		NA
855.	25.13	An additional lining or bushing not required for interconnection cords operating at safety extra-low voltage		NA
856.	30.2	For parts of the appliance connected to the supply mains during the charging period, 30.2.3 applies		NA
857.		For other parts, 30.2.2 applies		NA
	<b>C</b>	<b>ANNEX C (NORMATIVE) AGEING TEST ON MOTORS</b>		
858.		Tests, as described, carried out when doubt with regard to the temperature classification of the insulation of a motor winding		NA
	<b>D</b>	<b>ANNEX D (NORMATIVE) THERMAL MOTOR PROTECTORS</b>		
859.		Applicable to appliances having motors that incorporate thermal motor protectors		NA



**LAB RECORDS**  
**FORM 201-4117-TRF-E**

page: 63/85

(Lab Record S/N):

**504231-E**

Seq. No	Paragraphs	Requirements	Results Measurements Remarks	Verdict
	<b>E</b>	<b>ANNEX E (NORMATIVE) NEEDLE FLAME TEST</b>		
860.		Needle-flame test carried out in accordance with IEC 60695-11-5, with the following modifications:		<b>NA</b>
	7	Severities		
861.		The duration of application of the test flame is 30 s ± 1 s		<b>NA</b>
	9	Test procedure		
862.	9.1	The specimen so arranged that the flame can be applied to a vertical or horizontal edge as shown in the examples of figure 1		<b>NA</b>
863.	9.2	The first paragraph does not apply		<b>NA</b>
864.		If possible, the flame is applied at least 10 mm from a corner		<b>NA</b>
865.	9.3	The test is carried out on one specimen		<b>NA</b>
866.		If the specimen does not withstand the test, the test may be repeated on two additional specimens, both withstanding the test		<b>NA</b>
	11	Evaluation of test results		
867.		The duration of burning not exceeding 30 s		<b>NA</b>
868.		However, for printed circuit boards, the duration of burning not exceeding 15 s		<b>NA</b>
	<b>F</b>	<b>ANNEX F (NORMATIVE) CAPACITORS</b>		
869.		Capacitors likely to be permanently subjected to the supply voltage, and used for radio interference suppression or voltage dividing, comply with the following clauses of IEC 60384-14, with the following modifications:		<b>NA</b>
	1.5	Terminology		
870.	1.5.3	Class X capacitors tested according to subclass X2		<b>NA</b>
871.	1.5.4	This subclause is applicable		<b>NA</b>
	1.6	Marking		
872.		Items a) and b) are applicable		<b>NA</b>
	3.4	Approval testing		
873.	3.4.3.2	Table II is applicable as described		<b>NA</b>



**LAB RECORDS**  
**FORM 201-4117-TRF-E**

page: 64/85

(Lab Record S/N):

**504231-E**

Seq. No	Paragraphs	Requirements	Results Measurements Remarks	Verdict
874.	4.1	Visual examination and check of dimensions		NA
875.		This subclause is applicable		NA
876.	4.2	Electrical tests		NA
877.	4.2.1	This subclause is applicable		NA
878.	4.2.5	This subclause is applicable		NA
879.	4.2.5.2	Only table IX is applicable		NA
880.		Values for test A apply		NA
881.		However, for capacitors in heating appliances the values for test B or C apply		NA
	4.12	Damp heat, steady state		
882.		This subclause is applicable		NA
883.		Only insulation resistance and voltage proof are checked		NA
	4.13	Impulse voltage		
884.		This subclause is applicable		NA
	4.14	Endurance		
885.		Subclauses 4.14.1, 4.14.3, 4.14.4 and 4.14.7 applicable		NA
886.	4.14.7	Only insulation resistance and voltage proof are checked		NA
887.		Visual examination, no visible damage		NA
	4.17	Passive flammability test		
888.		This subclause is applicable		NA
	4.18	Active flammability test		
889.		This subclause is applicable		NA
	<b>G</b>	<b>ANNEX G (NORMATIVE)</b> <b>SAFETY ISOLATING TRANSFORMERS</b>		
890.		The following modifications to this standard are applicable for safety isolating transformers:		NA
	7	Marking and instructions		
891.	7.1	Transformers for specific use marked with:		NA
892.		-name, trademark or identification mark of the manufacturer or responsible vendor		NA



**LAB RECORDS**  
**FORM 201-4117-TRF-E**

page: 65/85

(Lab Record S/N):

**504231-E**

Seq. No	Paragraphs	Requirements	Results Measurements Remarks	Verdict
893.		-model or type reference		NA
894.	17	Overload protection of transformers and associated circuits		NA
895.		F-safe transformers comply with subclause 15.5 of IEC 61558-1		NA
	22	Construction		
896.		Subclauses 19.1 and 19.1.2 of IEC 61558-2-6 are applicable		NA
897.	29	Clearances, creepage distances and solid insulation		NA
898.	29.1, 29.2 and 29.3	The distances specified in items 2a, 2c and 3 in table 13		NA
	<b>H</b>	<b>ANNEX H (NORMATIVE) SWITCHES</b>		
899.		Switches comply with the following clauses of IEC 61058-1, as modified		NA
900.		-The tests of IEC 61058-1 carried out under the conditions occurring in the appliance		NA
901.		-Before being tested, switches are operated 20 times without load		NA
	8	Marking and documentation		
902.		Switches are not required to be marked		NA
903.		However, switches that can be tested separately from the appliance marked with the manufacturer's name or trade mark and the type reference		NA
	13	Mechanism		
904.		The tests may be carried out on a separate sample		NA
905.	15	Insulation resistance and dielectric strength		NA
906.	15.3	Applicable for full disconnection and micro-disconnection		NA
	17	Endurance		
907.		Compliance is checked on three separate appliances or switches		NA
908.		For 17.2.4.4, the number of cycles is 10 000, unless otherwise specified in 24.1.3 of the relevant part 2 of IEC 60335		NA
909.		Switches for operation under no load and which can be operated only by a tool and switches operated by hand that are interlocked so that they cannot be operated under load, are not subjected to the tests		NA



**LAB RECORDS**  
**FORM 201-4117-TRF-E**

page: 66/85

(Lab Record S/N):

**504231-E**

Seq. No	Paragraphs	Requirements	Results Measurements Remarks	Verdict
910.		Subclauses 17.2.2 and 17.2.5.2 not applicable		<b>NA</b>
911.		The ambient temperature during the test is that occurring in the appliance during the test of Clause 11 in IEC 60335-1		<b>NA</b>
912.		Temperature rise of the terminals not more than 30 K above the temperature rise measured in clause 11 of IEC 60335-1		<b>NA</b>
	20	Clearances, creepage distances, solid insulation and coatings of rigid printed board assemblies		
913.		This clause is applicable to clearances and creepage distances for functional insulation, across full disconnection and micro-disconnection, as stated in table 24		<b>NA</b>
	<b>I</b>	<b>ANNEX I (NORMATIVE)</b> <b>MOTORS HAVING BASIC INSULATION THAT IS INADEQUATE FOR THE RATED VOLTAGE OF THE APPLIANCE</b>		
914.		The following modifications to this standard are applicable for motors having basic insulation that is inadequate for the rated voltage of the appliance:		<b>NA</b>
	8	Protection against access to live parts		
915.	8.1	Metal parts of the motor are considered to be bare live parts		<b>NA</b>
	11	Heating		
916.	11.3	Temperature rise of the body of the motor is determined instead of the temperature rise of the windings		<b>NA</b>
917.	11.8	Temperature rise of the body of the motor, where in contact with insulating material, not exceeding values in table 3 for the relevant insulating material		<b>NA</b>
	16	Leakage current and electric strength		
918.	16.3	Insulation between live parts of the motor and its other metal parts not subjected to the test		<b>NA</b>
919.	19	Abnormal operation		
920.	19.1	The tests of 19.7 to 19.9 not carried out		<b>NA</b>
	19.101	Appliance operated at rated voltage with each of the following fault conditions:		



**LAB RECORDS**  
**FORM 201-4117-TRF-E**

page: 67/85

(Lab Record S/N):

**504231-E**

Seq. No	Paragraphs	Requirements	Results Measurements Remarks	Verdict
921.		- short circuit of the terminals of the motor, including any capacitor incorporated in the motor circuit		NA
922.		short circuit of each diode of the rectifier		NA
923.		open circuit of the supply to the motor		NA
924.		open circuit of any parallel resistor, the motor being in operation		NA
925.		Only one fault simulated at a time, the tests carried out consecutively		NA
	22	Construction		
926.	22.101	For class I appliances incorporating a motor supplied by a rectifier circuit, the d.c. circuit being insulated from accessible parts of the appliance by double or reinforced insulation		NA
927.		Compliance checked by the tests specified for double and reinforced insulation		NA
	<b>J</b>	<b>ANNEX J (NORMATIVE) COATED PRINTED CIRCUIT BOARDS</b>		
928.		Testing of protective coatings of printed circuit boards carried out in accordance with IEC 60664-3 with the following modifications:		NA
	5.7	Conditioning of the test specimens		
929.		When production samples are used, three samples of the printed circuit board are tested		NA
	5.7.1	Cold		
930.		The test is carried out at -25°C		NA
	5.7.3	Rapid change of temperature		
931.		Severity 1 is specified		NA
	5.9	Additional tests		
932.		This subclause is not applicable.		NA



**LAB RECORDS**  
**FORM 201-4117-TRF-E**

page: 68/85

(Lab Record S/N):

**504231-E**

Seq. No	Paragraphs	Requirements	Results Measurements Remarks	Verdict
	<b>K</b>	<b>ANNEX K (NORMATIVE) OVERVOLTAGE CATEGORIES</b>		
933.		The information on overvoltage categories is extracted from IEC 60664-1		<b>P</b>
934.		Overvoltage category is a numeral defining a transient overvoltage condition		<b>P</b>
935.		Equipment of overvoltage category IV is for use at the origin of the installation		<b>NA</b>
936.		Equipment of overvoltage category III is equipment in fixed installations and for cases where the reliability and the availability of the equipment is subject to special requirements		<b>NA</b>
937.		Equipment of overvoltage category II is energy consuming equipment to be supplied from the fixed installation		<b>P</b>
938.		If such equipment is subjected to special requirements with regard to reliability and availability, overvoltage category III applies		<b>NA</b>
939.		Equipment of overvoltage category I is equipment for connection to circuits in which measures are taken to limit transient overvoltages to an appropriate low level		<b>NA</b>
	<b>L</b>	<b>ANNEX L (INFORMATIVE) GUIDANCE FOR THE MEASUREMENT OF CLEARANCES AND CREEPAGE DISTANCES</b>		
940.		Sequences for the determination of clearances and creepage distances		<b>P</b>
	<b>M</b>	<b>ANNEX M (NORMATIVE) POLLUTION DEGREE</b>		
		Pollution		
941.		The microenvironment determines the effect of pollution on the insulation, taking into account the microenvironment		<b>P</b>
942.		Means may be provided to reduce pollution at the insulation by effective enclosures or similar		<b>P</b>
943.		Minimum clearances specified where pollution may be present in the microenvironment		<b>P</b>
		For evaluating creepage distances, the following degrees of pollution in the microenvironment are established:		



**LAB RECORDS**  
**FORM 201-4117-TRF-E**

page: 69/85

**(Lab Record S/N): 504231-E**

Seq. No	Paragraphs	Requirements	Results Measurements Remarks	Verdict
944.		pollution degree 1: no pollution or only dry, non-conductive pollution occurs. The pollution has no influence		<b>NA</b>
945.		pollution degree 2: only non-conductive pollution occurs, except that occasionally a temporary conductivity caused by condensation is to be expected		<b>NA</b>
946.		pollution degree 3: conductive pollution occurs or dry non-conductive pollution occurs that becomes conductive due to condensation that is to be expected		<b>P</b>
947.		pollution degree 4: the pollution generates persistent conductivity caused by conductive dust or by rain or snow		<b>NA</b>
	<b>N</b>	<b>ANNEX N (NORMATIVE) PROOF TRACKING TEST</b>		
948.		The proof tracking test is carried out in accordance with IEC 60112 with the following modifications:		<b>NA</b>
	7	Test apparatus		
	7.3	Test solutions		
949.		Test solution A is used		<b>NA</b>
950.	10	Determination of proof tracking index (PTI)		<b>NA</b>
	10.1	Procedure		
951.		The proof voltage is 100V, 175V, 400V or 600V.....:		<b>NA</b>
952.		The last paragraph of Clause 3 applies		<b>NA</b>
953.		The test is carried out on five specimens		<b>NA</b>
954.		In case of doubt, additional test with proof voltage reduced by 25V, the number of drops increased to 100		<b>NA</b>
	10.2	Report		
955.		The report stating if the PTI value was based on a test using 100 drops with a test voltage of (PTI-25) V.		<b>NA</b>



**LAB RECORDS**  
**FORM 201-4117-TRF-E**

page: 70/85

(Lab Record S/N):

**504231-E**

Seq. No	Paragraphs	Requirements	Results Measurements Remarks	Verdict
	<b>O</b>	<b>ANNEX O (INFORMATIVE)</b> <b>SELECTION AND SEQUENCE OF THE TESTS OF CLAUSE 30</b>		
956.		Description of tests for determination of resistance to heat and fire		<b>P</b>
	<b>P</b>	<b>ANNEX P (INFORMATIVE)</b> <b>GUIDANCE FOR THE APPLICATION OF THIS STANDARD TO APPLIANCES USED IN WARM DAMP EQUABLE CLIMATES</b>		
957.		Modifications applicable for class 0 and 01 appliances having a rated voltage exceeding 150V, intended to be used in countries having a warm damp equable climate and that are marked WDaE		<b>NA</b>
958.		Modifications may also be applied to class 1 appliances having a rated voltage exceeding 150V, intended to be used in countries having a warm damp equable climate and that are marked WdaE, if liable to be connected to a supply mains that excludes the protective earthing conductor		<b>NA</b>
	5	General conditions for the tests		
959.	5.7	The ambient temperature for the tests of Clauses 11 and 13 is 40		<b>NA</b>
	7	Marking and instructions		
960.	7.1	The appliance marked with the letters WDaE		<b>NA</b>
961.	7.12	The instructions state that the appliance is to be supplied through a RCD having a rated residual operating current not exceeding 30 mA		<b>NA</b>
962.		The instructions state that the appliance is considered to be suitable for use in countries having a warm damp equable climate, but may also be used in other countries		<b>NA</b>
	11	Heating		
963.	11.8	The values of Table 3 are reduced by 15 K		<b>NA</b>
964.	13	Leakage current and electric strength at operating temperature		<b>NA</b>
965.	13.2	The leakage current for class I appliances not exceeding 0,5 mA		<b>NA</b>
	15	Moisture resistance		



**LAB RECORDS**  
**FORM 201-4117-TRF-E**

page: 71/85

(Lab Record S/N):

**504231-E**

Seq. No	Paragraphs	Requirements	Results Measurements Remarks	Verdict
966.	15.3	The value of t is 37 °C		NA
	16	Leakage current and electric strength		
967.	16.2	The leakage current for class I appliances not exceeding 0,5 mA		NA
	19	Abnormal operation		
968.	19.13	The leakage current test of 16.2 is applied in addition to the electric strength test of 16.3		NA
	<b>Q</b>	<b>ANNEX Q (INFORMATIVE) SEQUENCE OF TESTS FOR THE EVALUATION OF ELECTRONIC CIRCUITS</b>		
969.		Description of tests for appliances incorporating electronic circuits		NA
	<b>R</b>	<b>ANNEX R (NORMATIVE) SOFTWARE EVALUATION</b>		
970.		Programmable electronic circuits requiring software incorporating measures to control the fault/error conditions specified in table R.1 or R.2 validated in accordance with the requirements of this annex		NA
	R.1	Programmable electronic circuits using software		
971.		Programmable electronic circuits requiring software incorporating measures to control the fault/error conditions specified in table R.1 or R.2 constructed so that the software does not impair compliance with the requirements of this standard		NA
	R.2	Requirements for the architecture		
972.		Programmable electronic circuits requiring software incorporating measures to control the fault/error conditions specified in table R.1 or R.2 use measures to control and avoid software-related faults/errors in safety-related data and safety-related segments of the software.		NA
	R.2.1.1	Programmable electronic circuits requiring software incorporating measures to control the fault/error conditions specified in table R.2 have one of the following structures:		
973.		- single channel with periodic self-test and monitoring		NA
974.		- dual channel (homogenous) with comparison		NA
975.		- dual channel (diverse) with comparison		NA



**LAB RECORDS**  
**FORM 201-4117-TRF-E**

page: 72/85

(Lab Record S/N):

**504231-E**

Seq. No	Paragraphs	Requirements	Results Measurements Remarks	Verdict
		Programmable electronic circuits requiring software incorporating measures to control the fault/error conditions specified in table R.1 have one of the following structures:		
976.		- single channel with functional test		NA
977.		- single channel with periodic self-test		NA
978.		- dual channel without comparison		NA
	R.2.2	Measures to control faults/errors		
979.	R.2.2.1	When redundant memory with comparison is provided on two areas of the same component, the data in one area is stored in a different format from that in the other area.		NA
980.	R.2.2.2	Programmable electronic circuits with functions requiring software incorporating measures to control the fault/error conditions specified in table R.2 and that use dual channel structures with comparison, have additional fault/error detection means for any fault/errors not detected by the comparison.		NA
981.	R.2.2.3	For programmable electronic circuits with functions requiring software incorporating measures to control the fault/error conditions specified in table R.1 or R.2, means are provided for the recognition and control of errors in transmissions to external safety-related data paths.		NA
982.	R.2.2.4	For programmable electronic circuits with functions requiring software incorporating measures to control the fault/error conditions specified in table R.1 or R.2, the programmable electronic circuits incorporate measures to address the fault/errors in safety-related segments and data indicated in table R.1 and R.2 as appropriate.		NA
983.	R.2.2.5	For programmable electronic circuits with functions requiring software incorporating measures to control the fault/error conditions specified in table R.1 or R.2, detection of a fault/error occur before compliance with clause 19 is impaired.		NA
984.	R.2.2.6	The software is referenced to relevant parts of the operating sequence and the associated hardware functions.		NA
985.	R.2.2.7	Labels used for memory locations are unique		NA



**LAB RECORDS**  
**FORM 201-4117-TRF-E**

page: 73/85

**(Lab Record S/N): 504231-E**

Seq. No	Paragraphs	Requirements	Results Measurements Remarks	Verdict
986.	R.2.2.8	The software is protected from user alteration of safety-related segments and data		NA
987.	R.2.2.9	Software and safety-related hardware under its control is initialized and terminates before compliance with clause 19 is impaired		NA
	R.3	Measures to avoid errors		
	R.3.1	General		
		For programmable electronic circuits with functions requiring software incorporating measures to control the fault/error conditions specified in table R.1 or R.2, the following measures to avoid systematic fault in the software are applied		
988.		Software that incorporates measures used to control the fault/error conditions specified in table R.2 is inherently acceptable for software required to control the fault/error conditions specified in table R.1		NA
	R.3.2	Specification		
989.	R.3.2.1	Software safety requirements:	Software Id:	NA
990.		The specification of the software safety requirements includes the descriptions listed		NA
	R.3.2.2	Software architecture		
991.	R.3.2.2.1	<p>The specification of the software architecture includes the aspects listed</p> <ul style="list-style-type: none"> <li>- techniques and measures to control software faults/errors (refer to R.2.2);</li> <li>- interactions between hardware and software;</li> <li>- partitioning into modules and their allocation to the specified safety functions;</li> <li>- hierarchy and call structure of the modules (control flow);</li> <li>- interrupt handling;</li> <li>- data flow and restrictions on data access;</li> <li>- architecture and storage of data;</li> <li>- time-based dependencies of sequences and data</li> </ul>	Document ref. No:	NA



**LAB RECORDS**  
**FORM 201-4117-TRF-E**

page: 74/85

**(Lab Record S/N): 504231-E**

Seq. No	Paragraphs	Requirements	Results Measurements Remarks	Verdict
992.	R.3.2.2.2	The architecture specification is validated against the specification of the software safety requirements by static analysis		<b>NA</b>
	R.3.2.3	Module design and coding		
993.	R.3.2.3.1	Based on the architecture design, software is suitably refined into modules.		<b>NA</b>
994.		Software module design and coding is implemented in a way that is traceable to the software architecture and requirements.		<b>NA</b>
995.	R.3.2.3.2	Software code is structured		<b>NA</b>
996.	R.3.2.3.3	Coded software is validated against the module specification by static analysis.		<b>NA</b>
997.		The module specification is validated against the architecture specification by static analysis		<b>NA</b>
	R.3.3.3	Software validation		
998.		The software is validated with reference to the requirements of the software safety requirements specification		<b>NA</b>
		Compliance is checked by simulation of:		
999.		- input signals present during normal operation		<b>NA</b>
1000.		- anticipated occurrences		<b>NA</b>
1001.		- undesired conditions requiring system action		<b>NA</b>



**LAB RECORDS**  
**FORM 201-4117-TRF-E**

page: 75/85

(Lab Record S/N):

**504231-E**

TABLE R.1 <sup>5)</sup> – GENERAL FAULT/ERROR CONDITIONS						NA
Component <sub>1)</sub>	Fault/error	Acceptable measures <sup>2) 3)</sup>	Definitions See IEC 60730-1	Document reference for applied measure	Document reference for applied test	Ver- dict
1 CPU  1.1 Registers	Stuck at	Functional test, or  periodic self-test using either:  - static memory test, or  - word protection with single bit redundancy	H.2.16.5  H.2.16.6  H.2.19.6  H.2.19.8.2			NA
1.2 VOID						
1.3 Programme counter	Stuck at	Functional test, or  Periodic self-test, or  Independent time-slot monitoring, or  Logical monitoring of the programme sequence	H.2.16.5  H.2.16.6  H.2.18.10. 4  H.2.18.10. 2			NA
2 Interrupt handling and execution	No interrupt or too frequent interrupt	Functional test, or time-slot monitoring	H.2.16.5  H.2.18.10. 4			NA
3 Clock	Wrong frequency (for quartz synchroniz ed clock: harmonics/ sub- harmonics only)	Frequency monitoring, or time slot monitoring	H.2.18.10. 1  H.2.18.10. 4			NA
4. Memory  4.1 Invariable memory	All single bit faults	Periodic modified checksum, or multiple checksum, or word protection with single bit redundancy	H.2.19.3.1  H.2.19.3.2  H.2.19.8.2			NA
4.2 Variable memory	DC fault	Periodic static memory test, or  word protection with single bit redundancy	H.2.19.6  H.2.19.8.2			NA

[Q.M.]

- HEEQAC S.A -

( FORM APPROVAL : 01/02/2015

ISSUE :1])

103, KEFALLINIAS STR., 112 51 ATHENS GREECE – TEL.: +30-210-86.70.588 – FAX: +30-210-86.47.510  
e-mail: info@heeqac.gr - website: [www.heeqac.gr](http://www.heeqac.gr)



**(Lab Record S/N):**

**504231-E**

4.3 Addressing (relevant to variable and invariable memory)	Stuck at	Word protection with single bit redundancy including the address	H.2.19.8.2			<b>NA</b>
5 Internal data path	Stuck at DC fault	Word protection with single bit redundancy  Comparison of redundant CPUs by either:  - reciprocal comparison  - independent hardware comparator	H.2.19.8.2  H.2.18.15  H.2.18.3			<b>NA</b>
5.1 VOID						
5.2 Addressing	Wrong address	Word protection with single bit redundancy including the address	H.2.19.8.2			<b>NA</b>
6 External communication	Hamming distance 3	Word protection with multi-bit redundancy, or CRC – single work, or Transfer redundancy, or Protocol test	H.2.19.8.1  H.2.19.4.1  H.2.18.2.2  H.2.18.14			<b>NA</b>
6.1 VOID						
6.2 VOID						
6.3 Timing	Wrong point in time          Wrong sequence	Time-slot monitoring, or scheduled transmission Time-slot and logical monitoring, or  Comparison of redundant communication channels by either:  - reciprocal comparison  - independent hardware comparator  Logical monitoring, or time- slot monitoring, or Scheduled transmission (same options as for wrong point in time)	H.2.18.10. 4  H.2.18.18  H.2.18.10. 3  H.2.18.15  H.2.18.3  H.2.18.10. 2  H.2.18.10. 4			<b>NA</b>



**(Lab Record S/N):**

**504231-E**

			H.2.18.18			
7 Input/output periphery	Fault conditions specified in 19.11.2	Plausibility check  Comparison of redundant communication channels by either:  - reciprocal comparison  - independent hardware comparator	H.2.18.13   H.2.18.15  H.2.18.3			<b>NA</b>
7.1 VOID						<b>NA</b>
7.2 Analog I/O  7.2.1 A/D and D/A- converter	Fault conditions specified in 19.11.2	Plausibility check	H.2.18.13			<b>NA</b>
7.2.2 Analog multiplexer	Wrong addressing	Plausibility check	H.2.18.13			<b>NA</b>
8 VOID						<b>NA</b>
9 Custom chips <sup>4)</sup> e.g. ASIC, GAL, Gate array	Any output outside the static and dynamic functional specification	Periodic self-test	H.2.16.6			<b>NA</b>

NOTE A Stuck-at fault model denotes a fault model representing an open circuit or a non-varying signal level. A DC fault model denotes a stuck-at fault model incorporating short circuit between signal lines.

<sup>1)</sup> For fault/error assessment, some components are divided into their sub-functions.

<sup>2)</sup> For each sub-function in the table, the Table R.2 measure will cover the software fault/error.

<sup>3)</sup> Where more than one measure is given for a sub-function, these are alternatives.

<sup>4)</sup> To be divided as necessary by the manufacturer into sub-functions.

<sup>5)</sup> Table R.1 is applied according to the requirements of R.1 to R.2.2.9 inclusive.



(Lab Record S/N):

**504231-E**

10.1 TABLE: Power input deviation						P
Input deviation of/at:	P rated (W)	P measured (W)	dP	Required dP	Remark	
230V	4000	4053,43	+1,34%	+5%/-10%	<b>P</b>	
* INFORMATIONAL MEASUREMENT ONLY						
10.2 TABLE: Current deviation						N/A
Current deviation of/at:	I rated (A)	I measured (A)	dI	Required dI	Remark	
11.8 TABLE: Heating test, thermocouples						P
Test voltage (V) . . . . .:			247,36			
Ambient (°C) . . . . .:			22,87			
Thermocouple locations		dT (K)		Max. dT (K)		
Supply cord		16,13		50		
Thermostat (metal surface)		42,30		95		
Wiring		16,13		50		
Metal surface		1,44		--		
11.8 TABLE: Heating test, resistance method						NA
Test voltage (V) . . . . .:						
Ambient, t1 (°C) . . . . .:						
Ambient, t2 (°C) . . . . .:						
Temperature rise of winding		R1 (Ω)	R2 (Ω)	dT (K)	Μεγ. dT (K) Max. dT (K)	Insulation class
13.2 TABLE: Leakage current						P
Heating appliances: 1.15 x rated input . . . . .:			1,15 x 4000 = 4600 W		P	
Motor-operated and combined appliances: 1.06 x rated voltage					NA	
Leakage current between			I (mA)		Max. allowed I (mA)	
Measured on enclosure			0,1		3	
13.3 TABLE: Electric strength						P
Test voltage applied between:			Voltage (V)		Breakdown (Yes/No)	
Live parts and enclosure			1000		<b>P</b>	



(Lab Record S/N):

**504231-E**

Live parts and plastic parts of enclosure		3000		<b>P</b>		
<b>14</b>	<b>TABLE: Transient overvoltages</b>				<b>NA</b>	
Clearance between:	CI (mm)	Required CI (mm)	Rated impulse voltage (V)	Impulse test voltage (V)	Flashover (Yes/No)	
<b>16.2</b>	<b>TABLE: Leakage current</b>				<b>P</b>	
	Single phase appliances: 1.06 x rated voltage...:		1,06x230=243,8 V		<b>P</b>	
	Three phase appliances 1.06 x rated voltage divided by $\sqrt{3}$ :.....:				<b>NA</b>	
Leakage current between			I (mA)		Max. allowed I (mA)	
Measured on enclosure			<b>0,1</b>		<b>3</b>	
<b>16.3</b>	<b>TABLE: Electric strength</b>				<b>P</b>	
Test voltage applied between:					Breakdown / Flashover	
Live parts and enclosure			1250		No	
Live parts and plastic parts of enclosure			3000		No	
<b>17</b>	<b>TABLE: Overload protection, thermocouples measurements</b>				<b>NA</b>	
Test voltage (V). :			....VAC			
Ambient (°C). :			.....°C			
Thermocouple locations		dT (K)		Max. dT (K)		
<b>17</b>	<b>TABLE: Overload protection, resistance method</b>				<b>NA</b>	
Test voltage (V). .....						
Ambient, t1 (°C) .....						
Ambient, t2 (°C).....						
Temperature of winding		R1 (Ω)	R2 (Ω)	dT (K)	T (°C)	Max. T (°C)
<b>19</b>	<b>Abnormal operation conditions</b>				<b>P</b>	
Operational characteristics		YES/NO		Operational conditions		
Are there electronic circuits to control the appliance operation?		No				
Are there "off" or "stand-by" position?		No				
The unintended operation of the appliance results in dangerous malfunction?		No				



**(Lab Record S/N):**

**504231-E**

Sub-clause	Operating conditions description	Test results description	PEC <sup>1)</sup> description	EMP <sup>2)</sup> 19.11.4	Software type required	19.11.3 PEC <sup>1)</sup>	Final result
19.2							NA
19.3							NA
19.4							NA
19.5							NA
19.6							NA
19.7							NA
19.8							NA
19.9							NA
19.10							NA
19.11.2							NA
19.11.4.8							NA
19.101	24 h test as Clause 11 at 247,36 VAC, 4600 W, empty container.	See 19.13	NA	NA	NA	NA	<b>P</b>

Supplementary information:



<sup>1)</sup> PEC: protective electronic circuit

<sup>2)</sup> EMP: Electromagnetic protection

<b>19.7</b>	<b>TABLE: Abnormal operation, locked rotor/moving parts</b>						<b>NA</b>
	Test voltage (V) .....						
	Ambient, t <sub>1</sub> (°C) .....						
	Ambient, t <sub>2</sub> (°C).....						
Temperature of winding		R1 (Ω)	R2 (Ω)	dT (K)	T (°C)	Max. T (°C)	
<b>19.9</b>	<b>TABLE: Abnormal operation, running overload</b>						<b>NA</b>
	Test voltage (V) .....						
	Ambient, t <sub>1</sub> (°C) .....						
	Ambient, t <sub>2</sub> (°C).....						
Temperature of winding		R1 (Ω)	R2 (Ω)	dT (K)	T (°C)	Max. T (°C)	
<b>19.13</b>	<b>TABLE: Abnormal operation, temperature rises</b>					<b>P</b>	
Thermocouple locations			Max. temperature rise measured, dT (K)		Max. temperature rise limit, dT (K)		
Insulation of supply cord			15,1		150		



**(Lab Record S/N): 504231-E**

24.1 TABLE: Components information					P
Object / part No.	Manufacturer/ trademark	Type / model	Technical data	Standard	Mark(s) of conformity
Heating Element	KOULIERIS KOSTAS	A0-RTS	4000W, 230V~	EN 60335-1 EN 60335-2-21	CE
Alternative Heating Element	KLAPAKIS S.A.	---	4000W, 230V~	EN 60335-1 EN 60335-2-21	CE
Thermostat		R-T-S 3	20A, 250V~, T105, F.80 / S.110	EN 60730-1 EN 60730-2-9	CE,  , PG, 
Gland	---	PG135	---	EN 50262	CE

28.1 TABLE: Threaded part torque test				P
Threaded part identification	Diameter of thread (mm)	Column number (I, II, or III)	Applied torque ( Nm )	
Terminal screw	3,86	II	1,2	
Earthing Screw	3,86	II	1,2	
Enclosure screw	3,55	II	0,8	

29.1 TABLE: Clearances						P
Overvoltage category.....: II						
		Type of insulation:				
Rated impulse voltage (V):	Min. cl (mm)	Basic (mm)	Supplementary (mm)	Reinforced (mm)	Functional (mm)	Verdict / Remark
330	0,2* / 0,5 / 0,8**					NA
500	0,2* / 0,5 / 0,8**					NA
800	0,2* / 0,5 / 0,8**					NA
1500	0,5 / 0,8** / 1,0***					NA
2500	1,5 / <b>2.0</b> ***	4,2		37,4		P
4000	3,0 / 3,5***					NA
6000	5,5 / 6,0***					NA
8000	8,0 / 8,5***					NA
10000	11,0 / 11,5***					NA

Supplementary information:

\*) For tracks on printed circuit boards if pollution degree 1 and 2

\*\*\*) For pollution degree 3

\*\*\*\*) If the construction is affected by wear, distortion, movement of the parts or during assembly

29.2 TABLE: Creepage distances, basic, supplementary and reinforced insulation			P
Working voltage (V)	Pollution degree		

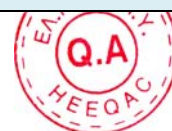

(Lab Record S/N):

**504231-E**

	1	2			3			Type of insulation			Verdict
		Material group			Material group			B**)	S**)	R**)	
		I	II	IIIa/IIIb	I	II	IIIa/IIIb*)				
≤50	0,18	0,6	0,85	1,2	1,5	1,7	1,9				NA
≤50	0,18	0,6	0,85	1,2	1,5	1,7	1,9				NA
≤50	0,36	1,2	1,7	2,4	3,0	3,4	3,8				NA
125	0,28	0,75	1,05	1,5	1,9	2,1	2,4				NA
125	0,28	0,75	1,05	1,5	1,9	2,1	2,4				NA
125	0,56	1,5	2,1	3,0	3,8	4,2	4,8				NA
250	0,56	1,25	1,8	2,5	3,2	3,6	<b>4.0</b>	X			P
250	0,56	1,25	1,8	2,5	3,2	3,6	<b>4.0</b>				NA
250	1,12	2,5	3,6	5,0	6,4	7,2	<b>8.0</b>			X	P
400	1,0	2,0	2,8	4,0	5,0	5,6	6,3				NA
400	1,0	2,0	2,8	4,0	5,0	5,6	6,3				NA
400	2,0	4,0	5,6	8,0	10,0	11,2	12,6				NA
500	1,3	2,5	3,6	5,0	6,3	7,1	8,0				NA
500	1,3	2,5	3,6	5,0	6,3	7,1	8,0				NA
500	2,6	5,0	7,2	10,0	12,6	14,2	16,0				NA
>630 and ≤800	1,8	3,2	4,5	6,3	8,0	9,0	10,0				NA
>630 and ≤800	1,8	3,2	4,5	6,3	8,0	9,0	10,0				NA
>630 and ≤800	3,6	6,4	9,0	12,6	16,0	18,0	20,0				NA
>800 and ≤1000	2,4	4,0	5,6	8,0	10,0	11,0	12,5				NA
>800 and ≤1000	2,4	4,0	5,6	8,0	10,0	11,0	12,5				NA
>800 and ≤1000	4,8	8,0	11,2	16,0	20,0	22,0	25,0				NA
>1000 and ≤1250	3,2	5,0	7,1	10,0	12,5	14,0	16,0				NA
>1000 and ≤1250	3,2	5,0	7,1	10,0	12,5	14,0	16,0				NA
>1000 and ≤1250	6,4	10,0	14,2	20,0	25,0	28,0	32,0				NA
>1250 and ≤1600	4,2	6,3	9,0	12,5	16,0	18,0	20,0				NA
>1250 and ≤1600	4,2	6,3	9,0	12,5	16,0	18,0	20,0				NA
>1250 and ≤1600	8,4	12,6	18,0	25,0	32,0	36,0	40,0				NA
>1600 and ≤2000	5,6	8,0	11,0	16,0	20,0	22,0	25,0				NA
>1600 and ≤2000	5,6	8,0	11,0	16,0	20,0	22,0	25,0				NA
>1600 and ≤2000	11,2	16,0	22,0	32,0	40,0	44,0	50,0				NA
>2000 and ≤2500	7,5	10,0	14,0	20,0	25,0	28,0	32,0				NA
>2000 and ≤2500	7,5	10,0	14,0	20,0	25,0	28,0	32,0				NA
>2000 and ≤2500	15,0	20,0	28,0	40,0	50,0	56,0	64,0				NA
>2500 and ≤3200	10,0	12,5	18,0	25,0	32,0	36,0	40,0				NA
>2500 and ≤3200	10,0	12,5	18,0	25,0	32,0	36,0	40,0				NA



(Lab Record S/N):

**504231-E**

>2500 and ≤3200	20,0	25,0	36,0	50,0	64,0	72,0	80,0				NA
>3200 and ≤4000	12,5	16,0	22,0	32,0	40,0	45,0	50,0				NA
>3200 and ≤4000	12,5	16,0	22,0	32,0	40,0	45,0	50,0				NA
>3200 and ≤4000	25,0	32,0	44,0	64,0	80,0	90,0	100,0				NA
>4000 and ≤5000	16,0	20,0	28,0	40,0	50,0	56,0	63,0				NA
>4000 and ≤5000	16,0	20,0	28,0	40,0	50,0	56,0	63,0				NA
>4000 and ≤5000	32,0	40,0	56,0	80,0	100,0	112,0	126,0				NA
>5000 and ≤6300	20,0	25,0	36,0	50,0	63,0	71,0	80,0				NA
>5000 and ≤6300	20,0	25,0	36,0	50,0	63,0	71,0	80,0				NA
>5000 and ≤6300	40,0	50,0	72,0	100,0	126,0	142,0	160,0				NA
>6300 and ≤8000	25,0	32,0	45,0	63,0	80,0	90,0	100,0				NA
>6300 and ≤8000	25,0	32,0	45,0	63,0	80,0	90,0	100,0				NA
>6300 and ≤8000	50,0	64,0	90,0	126,0	160,0	180,0	200,0				NA
>8000 and ≤10000	32,0	40,0	56,0	80,0	100,0	110,0	125,0				NA
>8000 and ≤10000	32,0	40,0	56,0	80,0	100,0	110,0	125,0				NA
>8000 and ≤10000	64,0	80,0	112,0	160,0	200,0	220,0	250,0				NA
>10000 and ≤12500	40,0	50,0	71,0	100,0	125,0	140,0	160,0				NA
>10000 and ≤12500	40,0	50,0	71,0	100,0	125,0	140,0	160,0				NA
>10000 and ≤12500	80,0	100,0	142,0	200,0	250,0	280,0	320,0				NA

Supplementary information:

\*) Material group IIIb is allowed if the working voltage does not exceed 50 V

\*\*\*) B = Basic insulation, S = Supplementary insulation, R = Reinforced insulation

<b>29.2</b>	<b>TABLE: Creepage distances, basic, functional insulation</b>							<b>NA</b>
Working voltage (V)	Pollution degree							
	1	2			3			
		Material group			Material group			
		I	II	IIIa/IIIb	I	II	IIIa/IIIb <sup>*)</sup>	Verdict / Remark
≤10	0,08	0,4	0,4	0,4	1,0	1,0	1,0	NA
50	0,16	0,56	0,8	1,1	1,4	1,6	1,8	NA
125	0,25	0,71	1,0	1,4	1,8	2,0	2,2	NA
250	0,42	1,0	1,4	2,0	2,5	2,8	3,2	NA
400	0,75	1,6	2,2	3,2	4,0	4,5	5,0	NA
500	1,0	2,0	2,8	4,0	5,0	5,6	6,3	NA
>630 and ≤800	1,8	3,2	4,5	6,3	8,0	9,0	10,0	NA
>800 and ≤1000	2,4	4,0	5,6	8,0	10,0	11,0	12,5	NA
>1000 and ≤1250	3,2	5,0	7,1	10,0	12,5	14,0	16,0	NA
>1250 and ≤1600	4,2	6,3	9,0	12,5	16,0	18,0	20,0	NA



**(Lab Record S/N):**

504231-E

>1600 and ≤2000	5,6	8,0	11,0	16,0	20,0	22,0	25,0	NA
>2000 and ≤2500	7,5	10,0	14,0	20,0	25,0	28,0	32,0	NA
>2500 and ≤3200	10,0	12,5	18,0	25,0	32,0	36,0	40,0	NA
>3200 and ≤4000	12,5	16,0	22,0	32,0	40,0	45,0	50,0	NA
>4000 and ≤5000	16,0	20,0	28,0	40,0	50,0	56,0	63,0	NA
>5000 and ≤6300	20,0	25,0	36,0	50,0	63,0	71,0	80,0	NA
>6300 and ≤8000	25,0	32,0	45,0	63,0	80,0	90,0	100,0	NA
>8000 and ≤10000	32,0	40,0	56,0	80,0	100,0	110,0	125,0	NA
>10000 and ≤12500	40,0	50,0	71,0	100,0	125,0	140,0	160,0	NA

Supplementary information:

\*) Material group IIIb is allowed if the working voltage does not exceed 50 V



(Lab Record S/N):

**504002-1-E**

<b>30</b>																				<b>TABLE: Resistance to heat and fire</b>																			
Object/ part No.	Manufacturer/ trademark	Type/ Model	Ball pressure test °C				Glow wire test (GWT) °C				Glow-wire flammability index (GWFI) °C				Glow- wire ignition temp. (GWIT) °C		Needle - flame test (NFT)	Verdict																					
			75	125	cl. 11 +40	cl. 19 +25	550	650		750		850	550	650	750	850			675	775																			
Thermostat Plastic cover				X				X						X							P																		

Supplementary information:

- 1) Parts of material classified at least HB40 or if relevant HBF
- 2) Parts of material classified as V-0 or V-1
- 3) Flame persisting longer than 2 s (= te – ti) need only be reported for unattended appliances
- 4) Surrounding parts subjected to the needle-flame test of annex E
- 5) Base material classified as V-0 or if relevant VTM-0
- 6) The GWIT pre-selection option, the 850 °C GWFI pre-selection option, and the 850 °C GWT are not applicable for attended appliances



**TEST ITEM IDENTITY AND ASSEMBLY INFORMATION**  
**FORM 202-E**

LAB RECORD S/N: **504231-E**

SAMPLE/S REMAINED IN HEEQAC

YES

NO

Different views of the EUT/S:

**Copy of marking plate**

The artwork below may be only a draft. The use of certification marks on a product must be authorized by the respective NCBs that own these marks

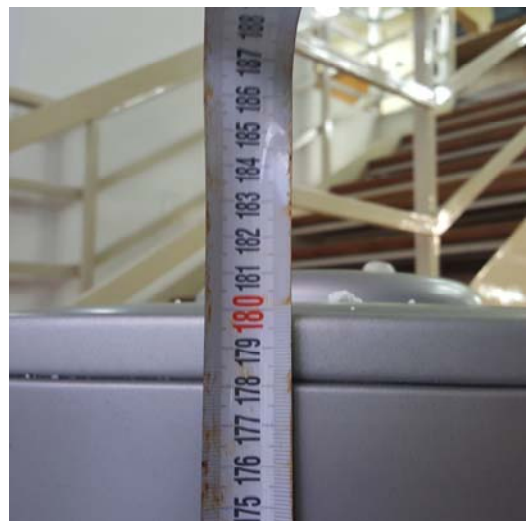

LAB RECORD S/N:

504231-E

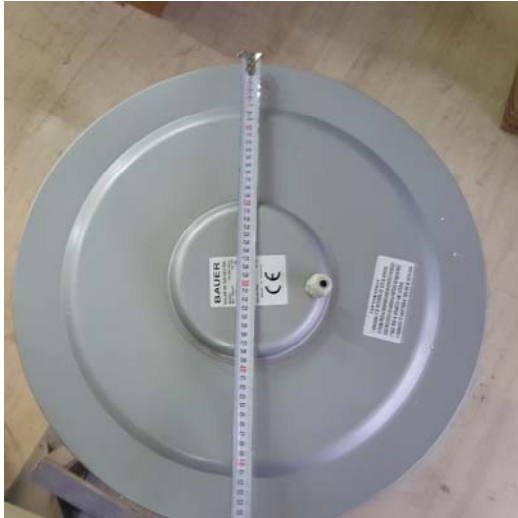

LAB RECORD S/N:

504231-E

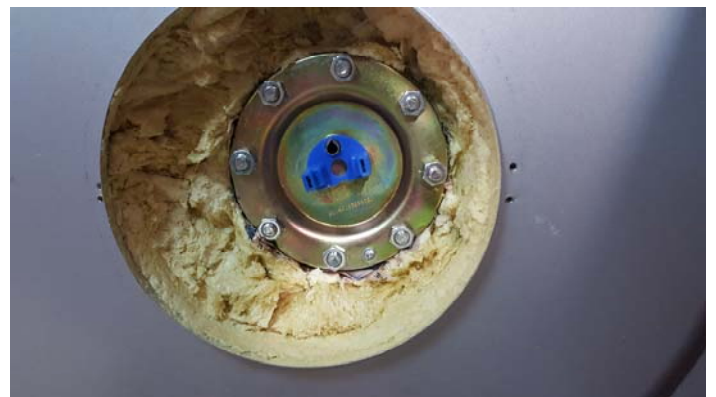

LAB RECORD S/N:

**504231-E****Copy of marking plate(s) of Type Variations (not submitted for testing)**

The artwork(s) below may be only a draft. The use of certification marks on a product must be authorized by the respective NCBs that own these marks.

**BAUER****SOLAR DEVICE**

MODEL: VR:300 Inox  
 NET WEIGHT: Kg XXX  
 RATED CAPACITY L: 300  
 SERIAL No: XXXXXX  
 RATED PRESSURE: 1MPa  
 TEST PRESSURE: 2MPa  
 RATED VOLTAGE: 230V~  
 RATED FREQUENCY: 50Hz  
 RATED POWER: 4kW  
 PROTECTION: IP24

Made: in Greece

**BAUER****SOLAR DEVICE**

MODEL: VR:250 Glass  
 NET WEIGHT: Kg XXX  
 RATED CAPACITY L: 250  
 SERIAL No: XXXXXX  
 RATED PRESSURE: 1MPa  
 TEST PRESSURE: 2MPa  
 RATED VOLTAGE: 230V~  
 RATED FREQUENCY: 50Hz  
 RATED POWER: 4kW  
 PROTECTION: IP24

Made: in Greece

**BAUER****SOLAR DEVICE**

MODEL: VR:250 Inox  
 NET WEIGHT: Kg XXX  
 RATED CAPACITY L: 250  
 SERIAL No: XXXXXX  
 RATED PRESSURE: 1MPa  
 TEST PRESSURE: 2MPa  
 RATED VOLTAGE: 230V~  
 RATED FREQUENCY: 50Hz  
 RATED POWER: 4kW  
 PROTECTION: IP24

Made: in Greece

**BAUER****SOLAR DEVICE**

MODEL: VR:200 Glass  
 NET WEIGHT: Kg XX  
 RATED CAPACITY L: 200  
 SERIAL No: XXXXXX  
 RATED PRESSURE: 1MPa  
 TEST PRESSURE: 2MPa  
 RATED VOLTAGE: 230V~  
 RATED FREQUENCY: 50Hz  
 RATED POWER: 4kW  
 PROTECTION: IP24

Made: in Greece



LAB RECORD S/N:

**504231-E****BAUER****SOLAR DEVICE**

MODEL: VR:200 Inox  
 NET WEIGHT: Kg XX  
 RATED CAPACITY L: 200  
 SERIAL No: XXXXXX  
 RATED PRESSURE: 1MPa  
 TEST PRESSURE: 2MPa  
 RATED VOLTAGE: 230V~  
 RATED FREQUENCY: 50Hz  
 RATED POWER: 4kW  
 PROTECTION: IP24

Made: in Greece

**BAUER****SOLAR DEVICE**

MODEL: VR:160 Glass  
 NET WEIGHT: Kg XX  
 RATED CAPACITY L: 160  
 SERIAL No: XXXXXX  
 RATED PRESSURE: 1MPa  
 TEST PRESSURE: 2MPa  
 RATED VOLTAGE: 230V~  
 RATED FREQUENCY: 50Hz  
 RATED POWER: 4kW  
 PROTECTION: IP24

Made: in Greece

**BAUER****SOLAR DEVICE**

MODEL: VR:160 Inox  
 NET WEIGHT: Kg XX  
 RATED CAPACITY L: 160  
 SERIAL No: XXXXXX  
 RATED PRESSURE: 1MPa  
 TEST PRESSURE: 2MPa  
 RATED VOLTAGE: 230V~  
 RATED FREQUENCY: 50Hz  
 RATED POWER: 4kW  
 PROTECTION: IP24

Made: in Greece

**BAUER****SOLAR DEVICE**

MODEL: VR:120 Glass  
 NET WEIGHT: Kg XX  
 RATED CAPACITY L: 120  
 SERIAL No: XXXXXX  
 RATED PRESSURE: 1MPa  
 TEST PRESSURE: 2MPa  
 RATED VOLTAGE: 230V~  
 RATED FREQUENCY: 50Hz  
 RATED POWER: 4kW  
 PROTECTION: IP24

Made: in Greece



LAB RECORD S/N:

**504231-E****BAUER****SOLAR DEVICE**

MODEL: VR:120 Inox  
NET WEIGHT: Kg XX  
RATED CAPACITY L: 120  
SERIAL No: XXXXXX  
RATED PRESSURE: 1MPa  
TEST PRESSURE: 2MPa  
RATED VOLTAGE: 230V~  
RATED FREQUENCY: 50Hz  
RATED POWER: 4kW  
PROTECTION: IP24

**Made: in Greece**



**LABORATORY DATA**

**FORM 203-E**

**PAGES: 1 / 1**

**LAB RECORD S/N:**

**504231-E**

Attached herewith you will find the following documents:

1. Installation manual

PAGES : 6

**TOTAL PAGES :**

**6**



# BAUER

Solar Systems

## SOLAR DEVICE

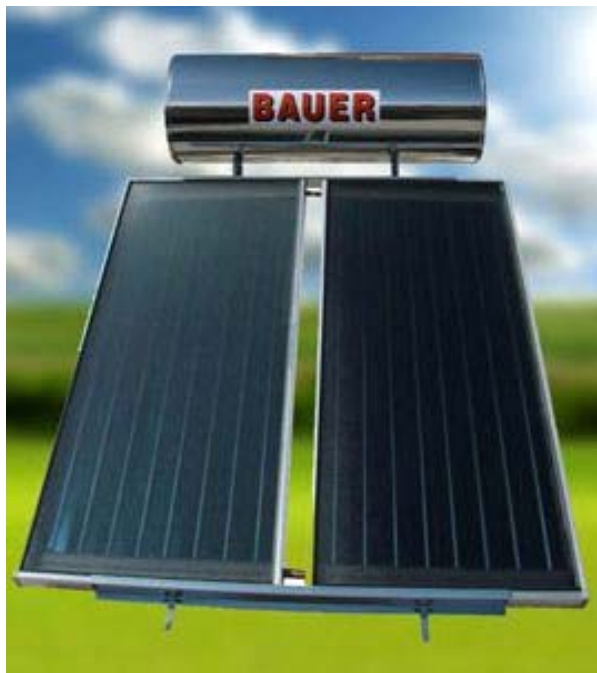

## INSTALLATION MANUAL

	<p> <b>WARNING</b></p> <p>Read and understand this instruction manual and safety messages before installing, operating or servicing this water heater. Failure to follow these instructions and safety messages could result in death or serious injury. This manual must remain with water heater.</p>
--	--

Keep this manual in the pocket on heater for future reference whenever maintenance adjustment or service is required.

504231-E





**ATTENTION:**

	Pressure-relief device is to be fitted in the installation, unless it is incorporated in the appliance.
	This appliance can be used by children aged from 8 years and above and persons with reduced physical, sensory or mental capabilities or lack of experience and knowledge if they have been given supervision or instruction concerning use of the appliance in a safe way and understand the hazards involved.
	Children shall not play with the appliance.
	Cleaning and user maintenance shall not be made by children without supervision.
	the water may drip from the discharge pipe of the pressure-relief device and that this pipe must be left open to the atmosphere
	the pressure-relief device is to be operated regularly to remove lime deposits and to verify that it is not blocked
	a discharge pipe connected to the pressure-relief device is to be installed in a continuously downward direction and in a frost-free environment
	Disconnecting means must be incorporated in the fixed wiring, in accordance with the respective regulations
	Safety valve membrane: EVEM type 03, 10bar

504231-E



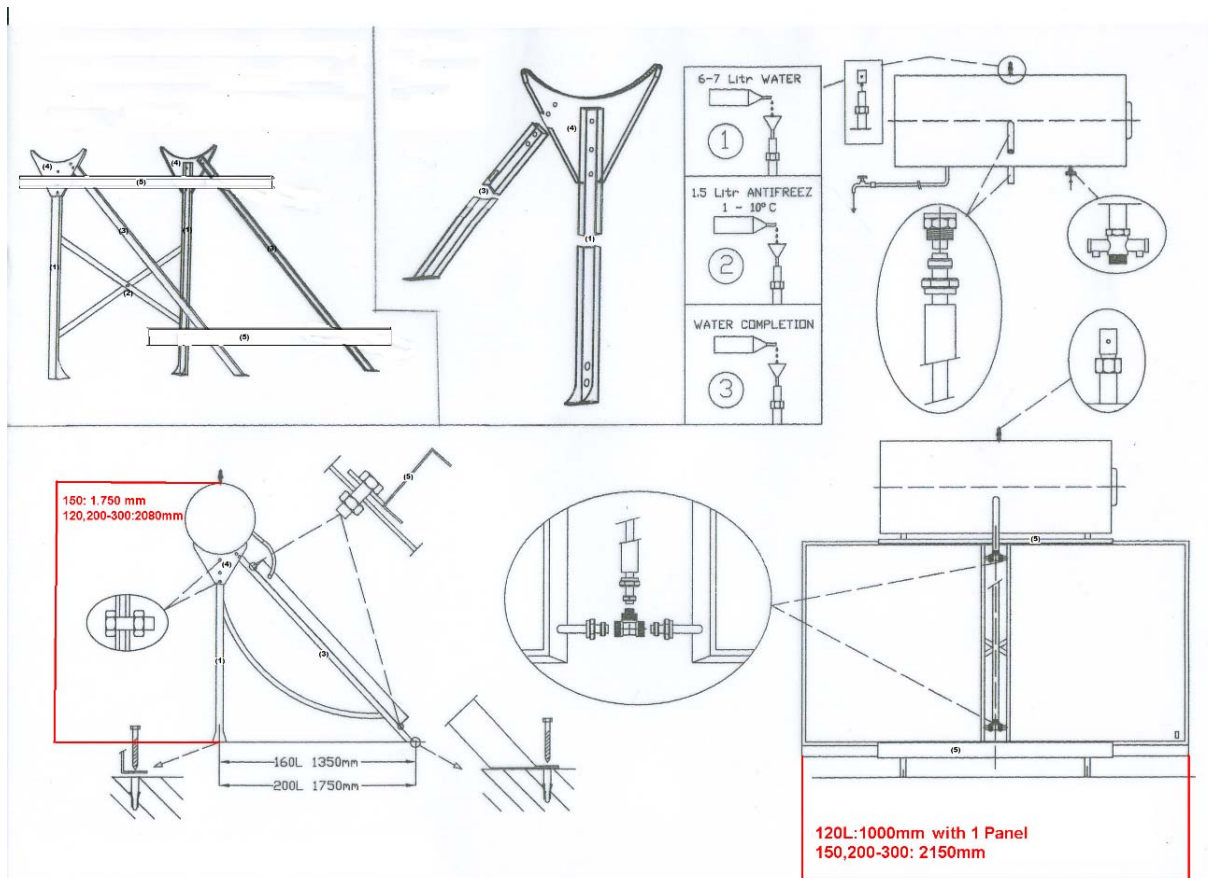

### **THE SUPPORT BASE**

The final form of the base is shown in drawing ( 1 )

The base consists of the following parts:

1. Rear vertical legs in Pi-shape with bending at the bottom: 2 pieces.
2. Sheets slightly wrinkled across their middle for the cross section: 2 pieces.
3. Front legs in Pi-shape - are always longer from the vertical: 2 pieces.
4. Boards in Y shape for the installation of the boiler: 2 pieces.
5. Bars in Pi-shape for the retaining of the collectors: 2 pieces.

### **ASSEMBLING PROCESS OF THE BASE**

1. Screw the two boards on the vertical legs.
2. screw together the two sheets of the cross section with a screw in their middle.
3. Screw the crosswise in two vertically (perpendicular P be both inward, he that the slot having the two boards are on the same side) drawing (2).



4. Screw the two front legs in the slot having the two boards (all P must be looking forward modes).
5. Screw one of the two gates P at the bottom of the oblique outriggers.
6. Tighten all the screws.
7. Place the collectors on the bottom bar of the base.
8. After you orient the base (the collectors to the south) screw the base to the floor (if straighten the legs back to the front), using the wall plugs and moly present in packaging.
9. Make sure all the screws are tightened and the base leveled.
10. System with two collectors, connect the two panels together by mechanical clamping T connection present in the package.
11. Place the pot in headboards of the base after the former have screwed Rakor 3/4 (provided) to the respective middle tubes with oblique tube is 3/4 to forward, to the side panels.
12. Screw one end of the plastic in the bottom T connection measure up tube 3/4 in the middle at the bottom of the boiler heater cut the tube and screw the Rakor.

The remaining piece of the tube would be screwed in the upper T connection and the corresponding oblique tube 3 / 4.13. Screwing the lock (provided) to the tube supply  $\frac{1}{2}$  the blue rosette at the bottom of the boiler heater, not tighten too much, then the locking screw a spherical knob, and then the water supply pipe. Then connect the consumption pipe in pipe  $\frac{1}{2}$  with the red rosette at the bottom of the boiler heater. Caution, not copper pipes to prevent electrolysis.

### **FILLING THE BOILER WITH WATER**

1. Open and leave open any hot water tap in the house.
2. Open the spherical switch provider and let the boiler heater to be filled with water.
3. After filling, close the faucet left open.

### **FILLING THE CIRCUIT**

#### **Maximum inlet pressure 1MPa**

1. Prepare a mixture of propylene glycol with water in a bucket.
2. Heat transfer medium Propylene glycol is used **(non-toxic)**
3. Propylene glycol must be admixed thoroughly with water, pouring into a bucket of propylene glycol and water mix well.
4. If you do not mingle very well, as heavier material will settle to the bottom of the panels so the solar panel does not work.
5. The circuit filling always be filled with the boiler heater full.
6. Fill the circuit by the tube  $\frac{1}{2}$  which is located at the top of the boiler heater.
7. The filling is considered finished when the overflow pipe and the level stays firmly packed.
8. Screw now the secure attachment.
9. Carefully check the connections for possible leaks.
10. The system is ready and began to work automatically.

504231-E



## CONNECTIONS OF THE ELECTRICAL RESISTANCE. (Cable replacement instructions)



**CAUTION, turn the power off the board.**

1. Remove the cap that covers the resistance by unscrewing the screws.
2. The thermostat connection is already executed by the manufacturer.
3. Pass the power cord through the hole in the cable gland located in the resistance cap.
4. Connect phase (brown to black wire) to the thermostat, marked **L**
5. Connect the neutral (blue wire) on the thermostat, marked **N**
6. Connect the ground (two color cable) to the corresponding screw flange resistance marked **ground**.
7. The thermostat is set at about 60, can be set at a different temperature. Do not set the thermostat above 75 degrees.
8. Screw the cap resistance.



**Do not switch on the power when the boiler heater is empty.**

### REPLACEMENT OF MAGNESIUM BAR.

All solar water heaters have a magnesium rod placed in the boiler heater (resistance) to prevent electrolysis.

1. Turn off the power switch and empty the water from the boiler heater.
2. Unscrew the cap resistance.
3. Disconnect the cables.
4. Remove the thermostat by pulling carefully.
5. Remove the eight screws that secure the resistance.
6. Unscrew the magnesium rod (worn) is the resistance.
7. Insert the new rod by tightening the well.
8. Replace the resistance in the cauldron neck with new gasket (rubber).



**CAUTION**

Preserve the pre-existing position of resistance.  
Replace the thermostat and cables as removed.  
Fill the boiler heater with water.



**CAUTION**

THE MAGNESIUM BAR SHALL NECESSARILY BE REPLACED EVERY TWO YEARS.

**Instructions for Draining the system:**

504231-E



**Turning Off the Water Heater.** If it is necessary to turn off the water heater on completion of the installation, such as on a building site or where the premises are vacant, then:

- switch off the electrical supply at the isolating switch to the water heater.
- Close the cold water isolation valve at the inlet to the water heater.

**Solar Storage Tank Draining**

To drain the solar storage tank:

1. Close all hot water taps.
2. Operate the relief valve release lever - do not let the lever snap back or you will damage the valve seat.
3. Operating the lever will release the pressure in the water heater.
4. Undo the joint at the cold water inlet to the solar storage tank and attach a hose to the water heater side of the union.
5. Let the other end of the hose go to a drain.
6. Operate the relief valve again.

This will let air into the water heater and allow the water to drain through the hose.

**Warning:**

the solar circuit may be under pressure. Take care when removing the solar circuit relief valve, as a sudden discharge of pressurized hot vapor may be experienced. This discharge will create a sharp sound of vapor being released.

Open the heat exchanger drain valve and remove the plug from the end of the hose. the closed circuit fluid will flood the hose.

Place the end of the hose into a container and drain the closed circuit fluid from the heat exchanger.

Note:

The heat exchanger can contain many liters of closed circuit fluid.

Contact Details:

BAUER HELLAS (Paterdis Dimitrios I.)

Chrysostomou Smyrnis 27 & Anexartissias, Zefyri, 13451, ATTICA

+302102621742

+302102322185

<http://bauerhellas.com>

504231-E

